



IC-FR3000/FR4000 Series Sales Handbook



Icom Inc.



FOREWORD and DISCLAIMER

Foreword

This handbook is prepared to provide detailed information about the IC-FR3000/FR4000 series VHF and UHF FM Repeaters.

Disclaimer

The information in this document has been carefully checked, and is believed to be correct and accurate. However, Icom assumes no responsibility for inaccuracies or mistakes. Furthermore, Icom reserves the right to make changes to any of the products described in this handbook without notice or obligation. The systems and applications described herein are for information and reference purposes only.

Handbook Revisions

Icom reserves the right to make changes to the content of this handbook at any time without notice or obligation.

IPR and Copyrights

The Icom products described in this handbook may include Icom Intellectual Property Rights (IPR) and/or copyrighted Icom computer programs stored in radio memories or other media/devices. Such IPR and copyrighted computer programs are protected by laws in Japan, the United States and other countries. Any Icom IPR and/or copyrighted Icom computer programs contained in the Icom products described in this manual may not be copied, reproduced, modified, reverse-engineered, or distributed in any way. Furthermore, the purchase of Icom products shall not be deemed to grant any license either directly or by implication, except for the normal non-exclusive license to use the product that is specified by law in the sale of a product.

Document Copyrights

No duplication or distribution of this document or any portion thereof shall take place without the express permission of Icom. Reproduction, distribution, or transmission for any purpose in any form or by any means, electronic or mechanical, shall only be allowed with the express permission of Icom.

Trademarks

Icom, Icom Inc. and the Icom logo are registered trademarks of Icom Incorporated (Japan) in the United States, the United Kingdom, Germany, France, Spain, Russia and/or other countries.

Microsoft, Windows and Windows Vista are either registered trademarks or trademarks of Microsoft Corporation in the United States and/or other countries.

All other products or brands are registered trademarks or trademarks of their respective holders.

Regarding Application Example

All application examples shown in this handbook are for your reference only. Icom has not tested or carried out performance check for many of these examples, so does not guarantee they will work if tried. We suggest you carry out testing before recommending to customers.



Table of Contents

Table of Contents

1	Introduction	
1-1	Company Profile	4
2	Overview	
2-1	Product Line Up	5
2-2	Common Features	6-7
2-3	Function and Specifications Comparison	
2-3-1	VHF FM Repeaters	8
2-3-2	UHF FM Repeaters	9
2-4	Optional Accessories	10
3	Operation and Function	
3-1	Panel Description	11-12
3-1-1	Functions Programmable to Keys	13
3-1-2	Display Assign	14
3-1-3	Connector Description	15-16
3-1-4	Installation and Connection	17-22
3-1-5	Optional Unit Installation	23
3-1-6	Duplexer and Isolator Installation	24-26
3-2	Cloning Software CS-FR3000	
3-2-1	Basic Setup of Cloning Software	27-29
3-2-2	Cloning Items	30
3-3	Operation	31
3-4	Repeater Backup	32
3-5	Multi-tone Function	33
3-6	Remote Control Function	
3-6-1	Remote Control Setting	34
3-6-2	Remote Control Operation	35
3-6-3	Command Table	36
3-6-4	Command Descriptions	37
3-6-5	Operation Example	38-44
3-7	Phone Patch	45-46
3-8	2-Tone (LMR) Signalling	47
3-9	5-Tone (PMR) Signalling	48-49
3-10	DTMF Signalling	50
3-11	Voice Scrambling System	51-52
4	Applications	
4-1	Repeater Linking System	53-55
4-1-1	Hardware / Software Setup	56
4-2	MPT1327 Trunking System	57-59
4-3	LTR® Trunking System	
4-3-1	Single Site LTR® Trunking System	60
4-3-2	Digital Networked LTR® or PassPort® Trunking System	61
4-3-3	Analog Networked LTR® or PassPort® Trunking System	62
4-4	Solar Powered Repeater System	63-65
4-5	Wind-Solar Hybrid Powered Repeater System	66-67
4-6	Wind and Solar Power Components	68
5	Maintenance	69-70
	Appendix	
A-1	Promotional Materials	71
A-2	Instruction Manual and Other Materials	72



1 Introduction

1-1 Company Profile

Company Profile

Icom, the wireless communication experts

Icom Inc. is a company located in Osaka, Japan, and is a manufacturer of wireless communication products. Since Icom's establishment in 1954, we have had a long record as a trusted manufacturer of land mobile radio, amateur radio, marine radio, navigation products, aviation radio and communications receivers.

Quality & Reliability

Icom quality and Icom reliability

Over 50 years of engineering and production excellence is a part of every Icom product. Using the latest equipment, Icom radios are tested to pass rigorous in-house tests as well as environmental tests to the US Military standard 810 specifications. Icom Inc holds ISO9001:2000 certification.

Production

Made in Japan quality

Icom is a rare example of an electronics manufacturer that has not shifted production to lower cost countries, but kept its production base 100% in Japan. The Wakayama Icom plant has an advanced production system to produce small volume/multi-model wireless communication products.

Icom brand

Icom, world brand name

Icom is today recognized as a reliable 2-way radio brand name around the world. Our land mobile radios are used by many professional organizations all over the world, like the United States Department of Defense and the U.S. Marine Corps. who chose Icom as the first Japanese company to supply radios to them.

Network

Icom's worldwide network

Icom's products are sold in over 80 countries in the World. Icom has an international sales and service network around the world, including sales subsidiaries in the US, Australia, Germany, Spain and liaison offices in France and China. Icom is here to support and service our products and your communication needs.



2 Overview

2-1 Product Line Up

VHF FM Repeater
IC-FR3000

UHF FM Repeater
IC-FR4000



Supplied Accessories

AC120V version

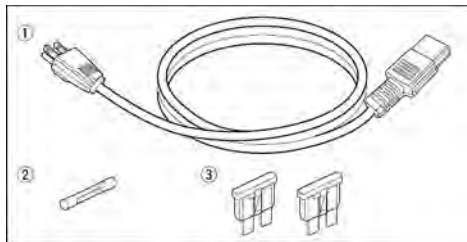

AC220V version

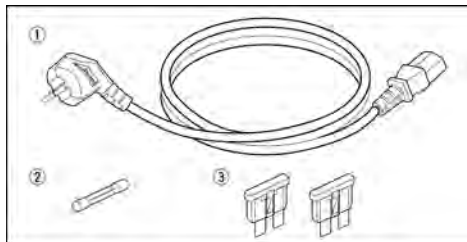

- ① AC power cable 1
OPC-510 (AC120V version) or
OPC-492 (AC220V version)
- ② Spare fuses (FGB 1 A) 1
- ③ Spare fuses (ATC 20) 2

Dimensions

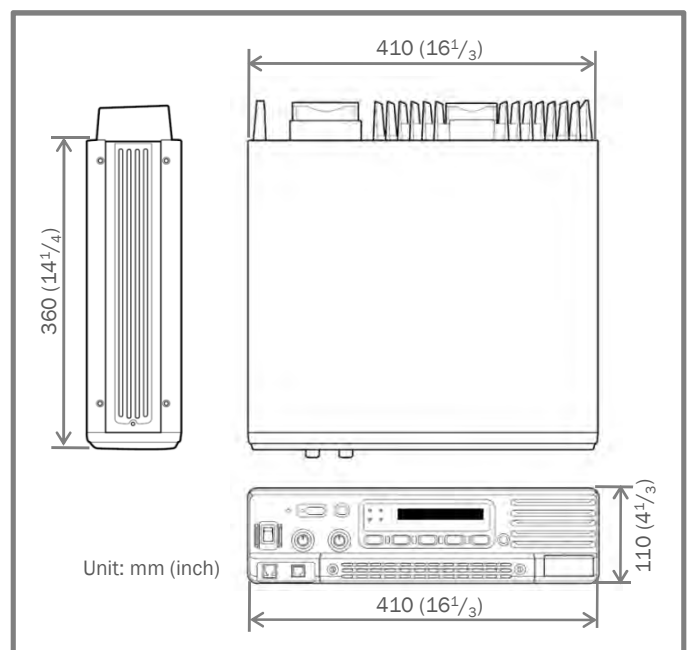



2-2 Common Features

ADVANCED POWERFUL REPEATERS

Icom's repeaters have been designed as advanced heavy duty performers to support all types of commercial radio applications. A host of standard features and guaranteed Icom performance means you'll need to look no further to satisfy your communication needs.

50 Watt continuous full duty cycle operation

This repeater performs as good as it looks. A rugged heatsink, large cooling fans and a high performance power module provide the repeater with a stable 50W at full duty cycle operation.

Automatic battery backup system

The repeater has a built-in power supply unit (100–120V or 220–240V AC). A built-in backup system supports automatic switching to an external power supply (13.6V DC) if the AC power supply fails.

32 memory channels

The repeater has 32 memory channels. Each memory channel stores a 10-character channel name, wide/narrow (25/12.5kHz) channel spacing, repeater/base operation etc, as well as frequency setting.

Multiple CTCSS/DTCS tone memories

Each channel has a max. 16 Rx and Tx CTCSS and DTCS tone memories that are freely programmable. These memories allow multiple groups to share a single channel.

Built-in 2-Tone, 5-Tone, DTMF encoder and decoder

Four 2-Tone codes, nine 5-Tone codes and 20 DTMF codes are programmable. You can also combine these tones with CTCSS or DTCS tones to control repeater access. These systems are fully compatible with Icom F-series radios.

ID transmission function

Own ID code or call sign can be sent at the beginning and/or end of the transmission. The ID code is used for identifying the repeater with the ANI (Automatic Number Identification) function. The ID format is selectable from CW, DTMF and 5-Tone.

Compatible with Trunking systems

The ACC connector (D-sub 25-pin) provides interfacing for on LTR®, PassPort® or MPT1327 trunking controller or control console.

5-Tone relay function

In a system that has 5-Tone capability, the repeater relay is opened by the matched 5-Tone signal. The repeater begins relaying the moment it receives the Repeater code. The Station and ID codes are relayed to the intended station.

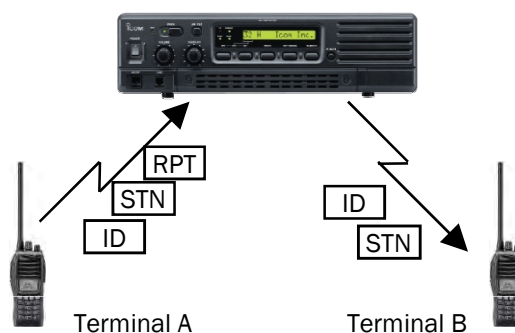

2-Tone/5-Tone auto TX function

When a matched 2-Tone/5-Tone code is received, the auto TX function automatically starts the transmission. The external source is selectable from MIC, ACC and Remote lines. With this function it is possible to listen to activity near the repeater itself from a remote location. This for example, allows you to know if unauthorized persons are near the repeater by being able to hear them talking.

Backup functions

An automatic alert function detects an internal error and alerts with a beep sound or a telephone call. If the repeater fails from an internal error, the Master repeater will automatically switchover to a sub-unit (Master/Slave switchover).

Optional Voice scrambler unit

The optional voice scrambler units, UT-109 or UT-110 provide secure communication by scrambling voice signals. Up to 32 codes with the UT-109 and 1020 codes (255 codes × 4 groups) with the UT-110 are available, respectively.



Common Features

Internal space for duplexer and isolator

The repeater has an internal space to install a duplexer and isolator*. The controls of the duplexer are accessible from the front of the repeater without disassembly. Faster and easier maintenance and adjustment is possible.

*Ask your dealer for details about available duplexers and isolators.

16-digit alphanumeric display

The 16-digit alphanumeric LCD displays channel number, channel name, decoded ID (with 2-Tone and DTMF), etc. Great for use as a base station.

Telephone interconnect capability

The repeater has a 4-pin modular connector allowing telephone interconnection.

DTMF remote control capability

You can control the repeater from a remote location over the air or over a phone line with DTMF.

Programmable key assign function

The following functions can be assigned to the [PROG] button.

- Priority A • Priority A (Rewrite)
- Display select • Lock
- High/Low • Wide/Narrow
- Call • Call A, B (PMR mode only)
- Emergency Single • Emergency Repeat
- Scrambler • Special Function 1, 2
- Null

Wall or rack mount available

With an optional microphone, the repeater can be placed on a desktop as a base station. The optional MB-77 wall mount bracket allows you to set the repeater on a wall. A 19" 3U height rack mount bracket, MB-78, is also available.



19-inch rack mount, MB-78



Installation on a wall with the MB-77

ADDITIONAL FEATURES

- Self check function checks for internal errors and alerts with a beep sound or with a phone call
- Compatible with VEGA tone remote control system
- CW ID transmitter (DTMF or 5-Tone also selectable)
- Password and kill/stun function for security

All trademarks are the properties of their respective holders.

Applicable U.S. Military Specifications

The **MIL-STD-810** series of standards are issued by the United States Army's Developmental Test Command, to specify various environmental tests to prove that equipment qualified to the standard will survive in the field.

icom makes rugged products that have been tested to and passed the following MIL-STD requirements and strict environmental standards.



Standard	MIL 810C		MIL 810D		MIL 810E		MIL 810F	
	Method	Proc.	Method	Proc.	Method	Proc.	Method	Proc.
High Temp.	501.1	I	501.2	I, II	501.3	I, II	501.4	I, II
Low Temp.	502.1	I	502.2	I, II	502.3	I, II	502.4-3	I, II
Vibration	514.2	VIII, X	514.3	I	514.4	I	514.5	I
Shock	516.2	I	516.3	I	516.4	I	516.5	I



2-3 Function and Specifications Comparison

2-3-1 VHF FM Repeaters

Model No.	IC-FR3000	IC-FR3000	IC-FR3000	IC-FR3000			
Version	#02	#12	#22	#23			
Destinations	USA-02	GEN-02	GEN-04	GEN-74			
Type Approval	FCC	Local T/A	Local T/A	Local T/A			
Function Comparison							
CTCSS	✓	✓	✓	✓			
DTCS	✓	✓	✓	✓			
2-Tone	✓	✓	✓	✓			
5-Tone	✓	✓	✓	✓			
DTMF Autodial	✓	✓	✓	✓			
DTMF Decoder	✓	✓	✓	✓			
BIIS 1200							
MDC 1200							
6.25kHz digital							
MPT 1327	✓ *1	✓ *1	✓ *1	✓ *1			
LTR® Trunking	✓ *1	✓ *1	✓ *1	✓ *1			
PassPort	✓ *1	✓ *1	✓ *1	✓ *1			
Intrinsically Safe							
SPECIFICATIONS							
GENERAL	Frequency Range (MHz)	150 ~ 174	150 ~ 174	150 ~ 174	148 ~ 172		
	Number of channels	32 ch		32 ch			
	Channel Spacing (kHz)	12.5/25		12.5/25			
	PLL channel step (Unit: kHz)	2.5* ² , 5, 6.25		2.5* ² , 5, 6.25			
	Power supply requirement	13.6V DC, 100-120V AC		13.6V DC, 220-240V AC			
	Current drain	Tx High	15A		15A		
		Rx	Stand-by	1A (typ.)		1A (typ.)	
			Max. audio	2A (typ.)		2A (typ.)	
	Dimensions (W × H × D) (projections not included)	410 × 110 × 360mm 16 ²³ / ₃₂ × 4 ¹¹ / ₃₂ × 14 ³ / ₁₆ in		410 × 110 × 360mm 16 ²³ / ₃₂ × 4 ¹¹ / ₃₂ × 14 ³ / ₁₆ in			
	Weight (approx.)	12kg; 26.4lb		12kg; 26.4lb			
TX	RF output power (High)	50W		50W			
	Spurious emissions	70dB (typ.)		70dB (typ.)			
	Adjacent channel power (W/N)	70/60dB (min.)		70/60dB (min.)			
RX	Sensitivity at 12dB SINAD	0.25μV (typ.)		0.25μV (typ.)			
	Adjacent channel selectivity (W/N)	70/60dB (typ.)		70/60dB (typ.)			
	Spurious response rejection	70dB (typ.)		70dB (typ.)			
	Intermodulation rejection	70dB (typ.)		70dB (typ.)			
	AF output power (at 5% distortion)	2.5W (typ.) with an 4Ω load		2.5W (typ.) with an 4Ω load			

*1 External controller required

*2 Repeater operation only



2-3 Function and Specifications Comparison









2-3-2 UHF FM Repeaters

Model No.	IC-FR4000	IC-FR4000	IC-FR4000	IC-FR4000	IC-FR4000	IC-FR4000	IC-FR4000	IC-FR4000		
Version	#01	#03	#11	#12	#13	#21	#22	#23		
Destinations	USA-01	USA-03	GEN-01	GEN-02	GEN-03	GEN-05	GEN-06	GEN-07		
Type Approval	FCC	FCC	Local T/A	Local T/A	Local T/A	Local T/A	Local T/A	Local T/A		
Function Comparison										
CTCSS	✓	✓	✓	✓	✓	✓	✓	✓		
DTCS	✓	✓	✓	✓	✓	✓	✓	✓		
2-Tone	✓	✓	✓	✓	✓	✓	✓	✓		
5-Tone	✓	✓	✓	✓	✓	✓	✓	✓		
DTMF Autodial	✓	✓	✓	✓	✓	✓	✓	✓		
DTMF Decoder	✓	✓	✓	✓	✓	✓	✓	✓		
BIIS 1200										
MDC 1200										
6.25kHz digital										
MPT 1327	✓ *1	✓ *1	✓ *1	✓ *1	✓ *1	✓ *1	✓ *1	✓ *1		
LTR® Trunking	✓ *1	✓ *1	✓ *1	✓ *1	✓ *1	✓ *1	✓ *1	✓ *1		
PassPort	✓ *1	✓ *1	✓ *1	✓ *1	✓ *1	✓ *1	✓ *1	✓ *1		
Intrinsically Safe										
SPECIFICATIONS										
GENERAL	Frequency Range (MHz)	400 ~ 430	450 ~ 480	400 ~ 430	430 ~ 450	450 ~ 480	400 ~ 430	430 ~ 450	450 ~ 480	
	Number of channels	32 ch								
	Channel Spacing (kHz)	12.5/25								
	PLL channel step (Unit: kHz)	5, 6.25								
	Power supply requirement	13.6V DC, 100-120V AC				13.6V DC, 220-240V AC				
	Current drain	Tx High	20A							
		Rx Stand-by	1A (typ.)							
		Max. audio	2A (typ.)							
	Dimensions (W × H × D) (projections not included)	410 × 110 × 360mm 16 ²³ / ₃₂ × 4 ¹¹ / ₃₂ × 14 ³ / ₁₆ in								
	Weight (approx.)	12kg; 26.4lb								
TX	RF output power (High)	50W								
	Spurious emissions	70dB (typ.)								
	Adjacent channel power (W/N)	70/60dB (min.)								
RX	Sensitivity at 12dB SINAD	0.25μV (typ.)								
	Adjacent channel selectivity (W/N)	70/60dB (typ.)								
	Spurious response rejection	70dB (typ.)								
	Intermodulation rejection	70dB (typ.)								
	AF output power (at 5% distortion)	2.5W (typ.) with an 4Ω load								

*1 External controller required

2-4 Optional Accessories

* Some optional accessories are not available in some countries.

MOUNTING BRACKETS		DESKTOP MICROPHONE	
 			
<p>MB-77 WALL MOUNT BRACKET For mounting the repeater on a wall. Hinges provide easy maintenance while mounted.</p>		<p>SM-25 : Convenient for dispatching, equipped with monitor switch.</p>	
<p>MB-78 19" RACK MOUNT BRACKET The 19 inch rack mount bracket is 3U height (133.5mm).</p>			
HAND MICROPHONES		CLONING CABLE	
 		 	
<p>HM-152 : Regular hand microphone.</p>		<p>OPC-592 : ADAPTOR CABLE</p>	
<p>HM-152T : DTMF microphone.</p>		<p>OPC-478 : CLONING CABLE</p>	
INTERNAL UNITS		CLONING SOFTWARE	
 		<p>CS-FR3000 : For programming versions of the IC-FR3000/FR4000 series VHF/UHF FM REPEATERS.</p>	
<p>UT-109 VOICE SCRAMBLER UNIT (Version 01) Provides operating security. Up to 32 non-rolling scrambling codes are available.</p>			
<p>UT-110 VOICE SCRAMBLER UNIT (Version 01) Up to 1020 (255 codes × 4 groups) rolling scrambling codes are available.</p>			

3 Operation and Function

3-1 Panel Description

Note: Operation of the functions described below may depend on radio programming.

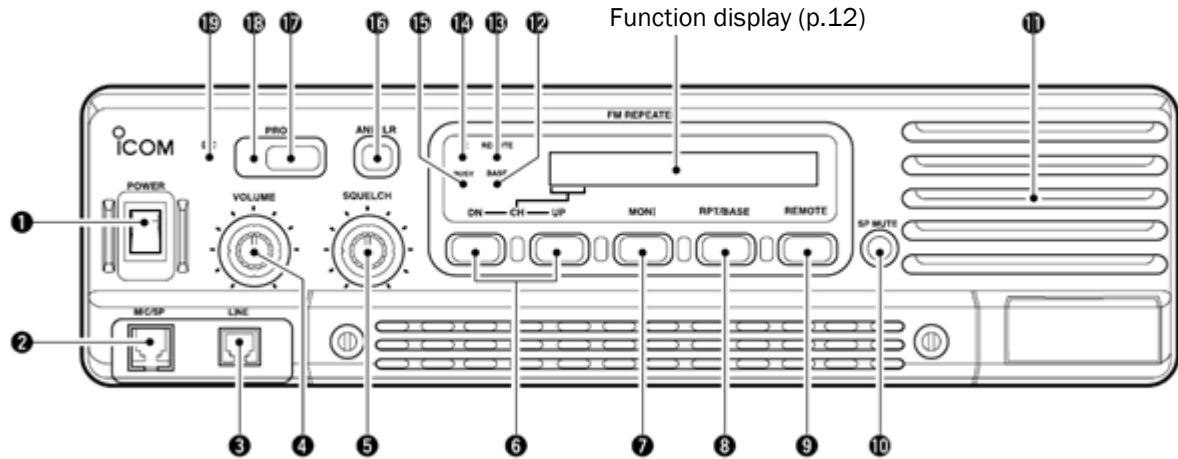

1 POWER SWITCH [POWER]

Toggles to turn the repeater power ON or OFF.

2 MICROPHONE/SPEAKER CONNECTOR [MIC/SP]

This 8-pin modular jack accepts the optional microphone.

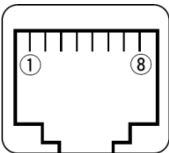

- ① +9 V DC output (Max. 10 mA)
- ② I/O port for PC programming
- ③ NC
- ④ M PTT (Input port for TX control)
- ⑤ Microphone ground
- ⑥ Microphone input
- ⑦ Ground
- ⑧ M MONI (Input port for monitor control)

3 LINE CONNECTOR [LINE]

This 4-pin modular jack accepts to connect to 2 wire system telephone cable.

- See p. 19 for line connector information.

4 VOLUME CONTROL [VOLUME] (p. 31)

Adjusts the audio output level.

5 SQUELCH CONTROL [SQUELCH]

- While in base operating mode, adjusts the squelch threshold level. (p. 31)
- While in repeater operating mode, this knob is not activate.

6 CHANNEL SELECT SWITCHES [DN/UP]

Push either switch to select the operating channel.

7 MONITOR SWITCH [MONI]

- Push to monitor the operating frequency.

8 MODE SELECT SWITCH [RPT/BASE]

Toggles the repeater or base operating mode when pushed.

- When setting up a repeater system using ICFR3000/FR4000 only, select a repeater operating mode.
- When using IC-FR3000/FR4000 as full (or half) duplex transceiver or setting up a repeater system connecting an external controller, select a base operating mode.

9 REMOTE CONTROL SWITCH [REMOTE]

Toggles to activate or inactivate the remote control operation when pushed.

10 AF MUTE CONTROL [SP MUTE]

Mutes the audio output.

11 INTERNAL SPEAKER

Monitors received signals.

12 BASE OPERATING MODE INDICATOR

Lights green while in base operating mode.

13 REMOTE CONTROL MODE INDICATOR

Lights green while in remote control operation.

14 TRANSMIT INDICATOR

Lights red while transmitting.

15 BUSY INDICATOR

Lights green while receiving a signal or when the noise squelch is open.

NOTE: Depends on the clone setting, BUSY indicator lights green while receiving a signal with a matched CTCSS/DCS signal.

16 ANI CLEAR SWITCH [ANI CLR]

Push for 1 sec. to clear the received ANI ID indication on the display and returns to original indication.

NOTE: This switch is no function available for some versions.

17 DEALER-PROGRAMMABLE SWITCH [PROG]

Toggles the pre-programmed function ON or OFF when pushed.

18 PROGRAMMED FUNCTION INDICATOR

Lights green while pre-programmed function is activated.

19 DC INDICATOR

Lights green when in DC operation.

Function display

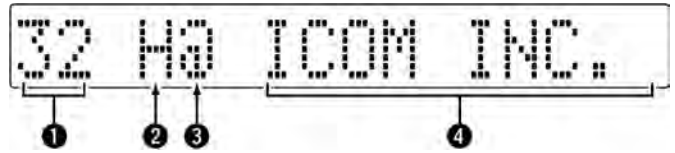

1 MEMORY CHANNEL INDICATOR

Shows the selected memory channel.

2 TRANSMIT POWER INDICATOR

Shows the output power level.

3 AUDIBLE INDICATOR

"@" appears in an audible condition, disappears in an inaudible condition. (When an audible condition, audio mute is cancelled.)

4 ALPHANUMERIC INDICATORS

Shows the variety text or code information.

Rear panel

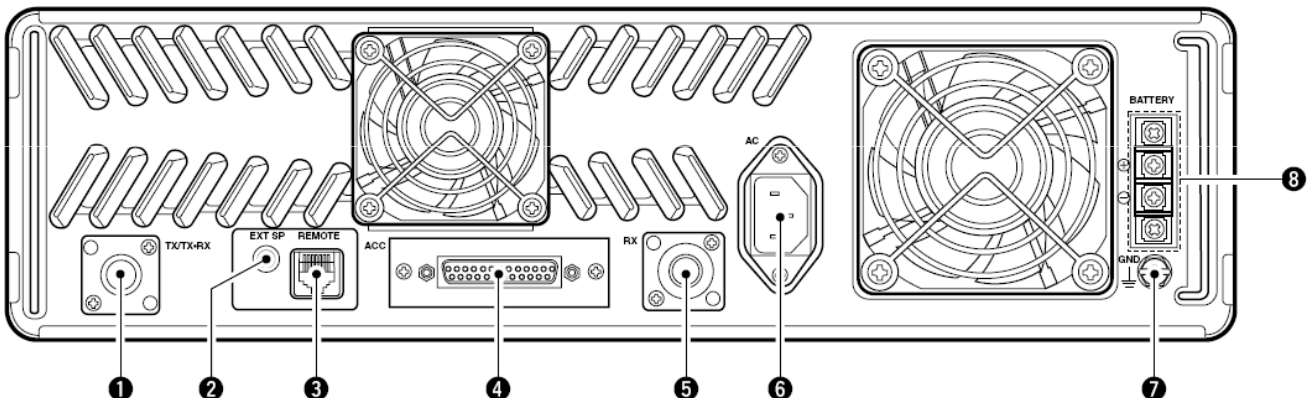

1 TRANSMIT ANTENNA CONNECTOR [TX/TX • RX]

Connects a transmit antenna (impedance: 50 Ω) and outputs transmit signals.

When installing an optional internal duplexer (supplied by third party), this connects the transmit receive to an antenna.

2 EXTERNAL SPEAKER CONNECTOR [EXT SP]

Accepts a 4 Ω external speaker.

3 REMOTE CONNECTOR [REMOTE]

Connects to the remote controller.

• See p. 16 for remote connector information.

4 ACCESSORY CONNECTOR [ACC]

Connects to the remote controller.

• See pgs. 15 for accessory connector information.

5 RECEIVE ANTENNA CONNECTOR [RX]

Connects a receive antenna (impedance: 50 Ω) and inputs receiving signals.

When installing an internal duplexer (supplied by third party), do not use this connector.

6 AC POWER SOCKET [AC]

Connects the supplied AC power cable to a domestic AC outlet.

7 GROUND TERMINAL [GND]

Ground the repeater through this terminal to prevent electric shocks, TVI, BCI and other problems.

8 DC POWER INPUT TERMINALS [BATTERY]

Connects the 12 V storage battery for the repeater backup when the AC power is interrupted. These terminals are also used for DC power operation.

CAUTION: NEVER short the (+) line of the DC power cable to repeater's chassis, when connecting DC power cable to the [BATTERY] terminals. Otherwise, there is danger of electric shock and/or equipment damage.



3-1-1 Functions Programmable to [PROG] Key

□ Key Assign

Dealer programmable key [PROG] can be programmed for one of several functions (see below).

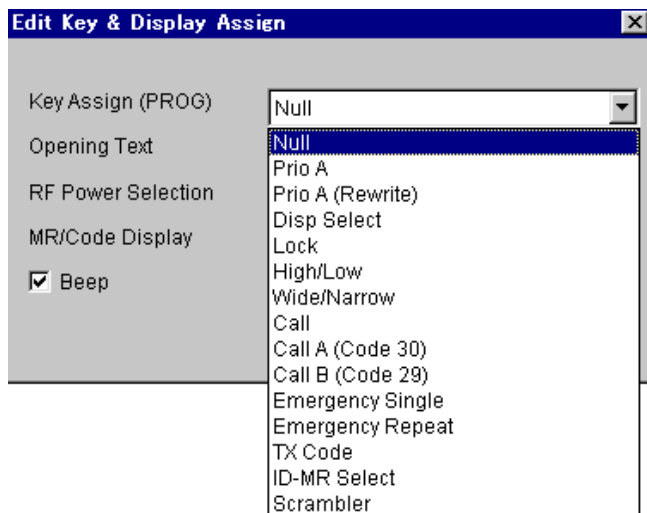

➤ Programmable Key Assign

- **Null**
 - No function.
- **Prio A**
 - Selects priority channel A.
- **Prio A (Rewrite)**
 - Push to select priority channel A. Push and hold to re-assign priority channel A.
- **Disp Select**
 - Push to select the display indication on normal operating mode.
Normal indication -> W/N indication -> TX frequency indication -> RX frequency indication -> DISPLAY OFF indication.
 - Push and hold to recall the received DTMF code. Use [CH UP]/[CH DN] keys for selection.
 - * Up to 10 codes can be memorized. Push and hold [ANI CLR] key to erase the received code on display.
- **Lock**
 - Turns the lock function ON and OFF.
- **High/ Low**
 - Changes the output power from the independent settings of each channel.
- **Wide/Narrow**
 - Each channel can be set to wide/narrow for both receive IF bandwidth and transmitter modulation.
- **Call (PMR)**
 - Transmits the 5Tone code on the selected channel.
- **Call (LMR)**
 - Transmits the 2Tone code on the selected channel.

- **Call A (code 30) (PMR)**
 - Transmits the 5Tone codes using TX code channels 30 for a station code.
- **Call B (code 29) (PMR)**
 - Transmits the 5Tone codes using TX code channels 29 for a station code.
- **Emergency Single/Repeat**
 - Transmits an emergency call once or repeatedly.
 - * The emergency channel is specified in the Memory CH screen (CH Atr column).
- **TX Code (PMR)**
 - Push to select a station code using [CH UP]/[CH DN] keys.
 - Push and hold to enter the selected code and change the contents of the code.
 - * The contents of the TX Code can be updated in the TX Code CH screen when the [Update] function is selected.
- **ID-MR Select (PMR)**
 - Push to recall the received 5-tone or ID code. Use [CH UP]/[CH DN] keys for selection.
 - * Up to 10 IDs can be memorized. Push and hold this or [ANI CLR] key to erase the received ID on display.
- **Scrambler**
 - Push to toggle the Scrambler function ON or OFF.
 - * Sets the Scrambler code number on Memory Channel screen in advance.

NOTE:

This setting is only effective for the base mode.

- **Sp. Func 1/2**
 - Reserved for future function.

➤ Scrambler Code

- Program the scrambler codes.
Available codes;
UT-109 (Non-rolling type) : 1 to 32
UT-110 (Rolling type) : 1 to 255

NOTE:

- Set the scrambler group code in the Common 2 screen in advance. (UT-110 only)
- UT-110 can be program the group number 1 to 4. Then totality 1020 (4 group * 255) code numbers are available.
- Set the scrambler type in the Common 2 screen. By selecting Non-rolling type in this item, you can use UT-110 as UT-109.
- This setting is only effective for the base mode.

RELATED ITEMS:

- Synchronous capture :Common 2 screen (UT-110 only)
- Tone Start Timing :Common 2 screen (UT-110 only)



3-1-2 Display Assign

Display Assign

Dealer programmable key [PROG] can be programmed for one of several functions (see below).

Key Assign (PROG) Null

Opening Text

RF Power Selection MR CH individual

MR/Code Display MR CH

Beep

OK Cancel

➤ Programmable Key Assign

• Opening Text

- This set text appears for 2 sec. when turning the repeater ON. To turn power ON without text indication, set this item to blank.

- Up to 16 characters are available.

- Usable characters: ! " # \$ % & ' () * + - , . / : ; < > = ? @ [] ^ _ ` { | } 0 to 9, A to Z, a to z and space.

• RF Power Selection

- MR CH individual

Output power keys, [High] and [Low], select power temporarily. Returns to the previous power when changing the channel.

- Override

Output power keys select the power permanently.

• MR/Code Display (PMR only)

Selects the indication text.

- MR CH

Operating channel's text.

- MR CH + TX CODE CH

Operating channel number and 10 letters of TX Code channel's text (or 7 digits of code contents when text is not programmed).

• Beep

Confirmation beep tones generally sound when you push a key or switch.

These can be turned ON or OFF to your preference.

You can program the repeater for silent operation or to have confirmation beeps sound.

□ Accessory connector

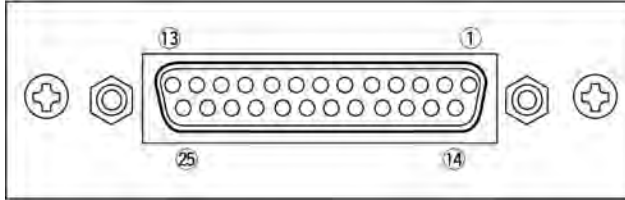

Pin No.	Pin Name	Description	Specification
1	BUSY OUT	Output terminal for busy signal.	Open collector=OFF, 0 V=ON
2	COAXIAL SW	Output terminal for coaxial switching (antenna switching) Signal.	Open collector=OFF, 0 V=ON
3	M/S IN	Input terminal for master/slave signal.	+5 V pull up, Active=L
4	D1	Input terminal for selecting memory channel.	+5 V pull up, Active=L
5	D3	Input terminal for selecting memory channel.	+5 V pull up, Active=L
6	EXT RPT/BASE	Input terminal for repeater/base operating mode switching signal.	+5 V pull up, Active=L
7	EXT MONI	Input terminal for monitor function.	+5 V pull up, Active=L
8	EXT DTCS	Input terminal for continuous tone (CTCSS/DTCS) signal.	Input impedance: 100 kΩ (approx.)
9	EXTMOD IN B	Input terminal for the modulation signals applied to input of the splutter filter circuit.	Input impedance: 600 Ω (approx.)
10	EXTMOD IN A	Input terminal for the modulation signal applied to input of the pre-emphasis circuit via the bandpass filter.	Input impedance: 600 Ω (approx.)
11	AF OUT	Output terminal for AF signals from the AF detector circuit via the bandpass filter. Output level is fixed, regardless of [AF] control.	Output impedance: 1 kΩ (approx.)
12	DISC OUT	Output terminal for AF signals from the AF detector circuit. Output level is fixed, regardless of [AF] control.	Output impedance: 1 kΩ (approx.)
13	+15V	Output terminal for +15V DC while in AC operation. (While in DC operation, same as input DC.)	Output current: Less than 1 A
14	TX OUT	Output terminal for transmission state.	Open collector=OFF, 0 V=ON
15	M/S OUT	Output terminal for master/slave signal.	Open collector=OFF, 0 V=ON
16	D0	Input terminal for selecting memory channel.	+5 V pull up, Active=L
17	D2	Input terminal for selecting memory channel.	+5 V pull up, Active=L
18	D4	Input terminal for selecting memory channel.	+5 V pull up, Active=L
19	EXT PTT	Input terminal for PTT signal.	+5 V pull up, Active=L
20	RSSI	Output terminal for RSSI (Received Signal Strength Indicator) Signal.	Output impedance: 1 kΩ (approx.)
21-24	AGND	Analog ground	
25	DC GND	Ground for +15 V DC	

- Pin 4, pin 5, pins 16–18 select one of the 32 pre-programmed memory channels. (see table below)
[0]: Hi-Z, [1]: 0 V (D0–D4: +5 V pull up)

Channel	D4 (pin 18)	D3 (pin 5)	D2 (pin 17)	D1 (pin 4)	D0 (pin16)	Channel	D4 (pin 18)	D3 (pin 5)	D2 (pin 17)	D1 (pin 4)	D0 (pin16)
1	0	0	0	0	0	17	1	0	0	0	0
2	0	0	0	0	1	18	1	0	0	0	1
3	0	0	0	1	0	19	1	0	0	1	0
4	0	0	0	1	1	20	1	0	0	1	1
5	0	0	1	0	0	21	1	0	1	0	0
6	0	0	1	0	1	22	1	0	1	0	1
7	0	0	1	1	0	23	1	0	1	1	0
8	0	0	1	1	1	24	1	0	1	1	1
9	0	1	0	0	0	25	1	1	0	0	0
10	0	1	0	0	1	26	1	1	0	0	1
11	0	1	0	1	0	27	1	1	0	1	0
12	0	1	0	1	1	28	1	1	0	1	1
13	0	1	1	0	0	29	1	1	1	0	0
14	0	1	1	0	1	30	1	1	1	0	1
15	0	1	1	1	0	31	1	1	1	1	0
16	0	1	1	1	1	32	1	1	1	1	1

Remote connector

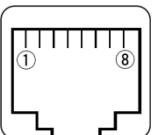
	Pin No.	Pin Name	Description	Specification
	1	-PTT	Input terminals to transmit the repeater in relation to the external equipment. An opto-isolator is provided to facilitate PTT signals.	High voltage=PTT ON (transmits) Hi-Z=PTT OFF
	2	+PTT		
	3	-AFOUT	Output terminal for AF signals from the AF detector circuit via the bandpass filter. Output level is fixed, regardless of [AF] control.	Output impedance: 600 Ω
	4	+AFOUT		
	5	-EXTMOD	Input terminal for the modulation circuit.	Input impedance: 600 Ω
	6	+EXTMOD		
	7	-BUSY	Output terminal for squelch condition (Open/Close). An opto-isolator is provided to facilitate BUSY signals.	Open collector=BUSY OFF 0 V=BUSY ON (Squelch is opened)
	8	+BUSY		

***About Remote connector (pins 7, 8) and Accessory connector (pin 1):**

Depends on the clone setting, BUSY signals are output while receiving a signal with a matched CTCSS/DCS signal.

❑ Unpacking

After unpacking, immediately report any damage to the delivering carrier or dealer. Keep the shipping cartons.

For a description and a diagram of accessory equipment included with the IC-FR3000/FR4000 series, see 'Supplied accessories' on page 5 of this manual.

❑ Selecting a location

Select a location for the repeater that allows adequate air circulation, free from extreme heat, cold, or vibrations, and away from TV sets, TV antenna elements, radios and other electromagnetic sources.

❑ Antenna connection

For radio communications, the antenna is of critical importance, along with output power and sensitivity. Select antenna(s), such as a well-matched 50 Ω antenna, and feedline. 1.5:1 or better of Voltage Standing Wave Ratio (VSWR) is recommended for desired band. Of course, the transmission line should be a coaxial cable.

CAUTION: Protect repeater from lightning by using a lightning arrestor.

NOTE: There are many publications covering proper antennas and their installation. Check with your local dealer for more information and recommendations

❑ Duplexer

A duplexer is separately required when only one antenna is used for both transmitting and receiving. Select a duplexer according to the transmitting and receiving frequencies. Ask your Dealer for details.

❑ Grounding

To prevent electrical shock, television interference (TVI), broadcast interference (BCI) and other problems, ground the transceiver through the [GND] terminal on the rear panel.

For best results, connect a heavy gauge wire or strap to a long earth-sunk copper rod. Make the distance between the [GND] terminal and ground as short as possible.

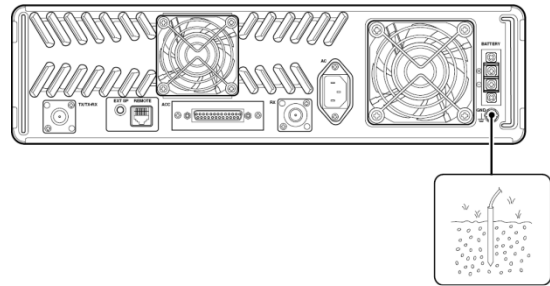

⚠ WARNING: NEVER connect the [GND] terminal to a gas or electric pipe, since the connection could cause an explosion or electric shock.

TYPE-N CONNECTOR INSTALLATION EXAMPLE

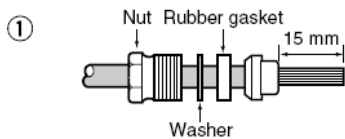

Slide the nut, flat washer, rubber gasket and clamp over the coaxial cable, then cut the end of the cable evenly.

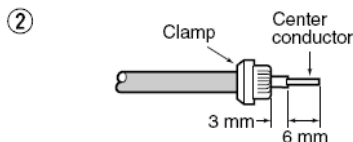

Strip the cable and fold the braid back over the clamp.

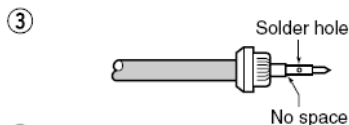

Soft solder the center conductor. Install the center conductor pin and solder it.

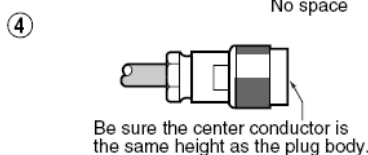

Carefully slide the plug body into place aligning the center conductor pin on the cable. Tighten the nut onto the plug body.

30 mm ≈ 1 1/8 in 10 mm ≈ 3/8 in 1-2 mm ≈ 1/16 in

□ Required connections

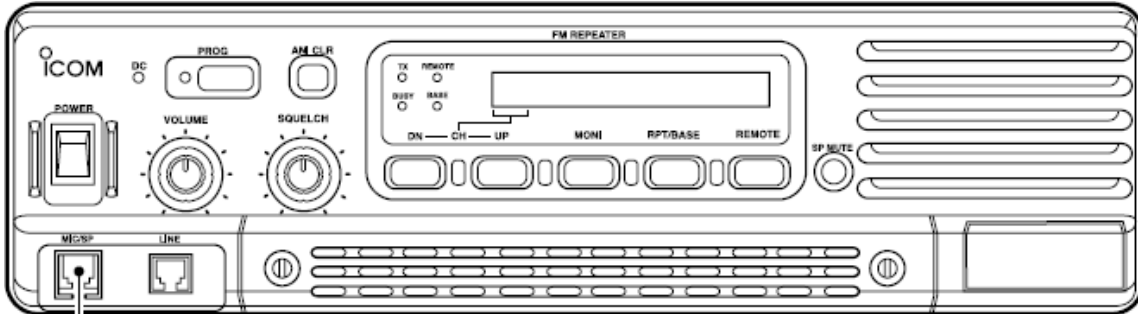

HM-152/T HAND MICROPHONE
(optional)



SM-25 DESKTOP MICROPHONE
(optional)



MICROPHONE CONNECTOR (Front panel view)

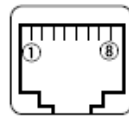

- ① +9 V DC output (Max. 10 mA)
- ② I/O port for PC programming
- ③ NC
- ④ M PTT (Input port for TX control)
- ⑤ Microphone ground
- ⑥ Microphone input
- ⑦ Ground
- ⑧ M MONI (Input port for monitor control)

CAUTION: DO NOT short pin 1 to ground as this can damage the internal 9 V regulator. DC voltage is applied to pin 1 for microphone operation. Take care when using a non-icom microphone.

[DC POWER INPUT TERMINAL] (p. 8)

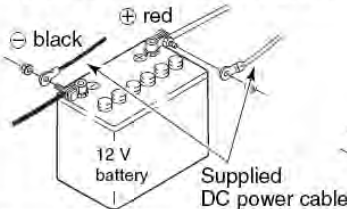

Crimp

Solder

Make sure the back up battery is correctly connected. Use a cable with following current capacity. Solder or clamp the cable lug when connecting the power cable to the backup battery to prevent voltage drops.

Power cable current capacity: 25 A or more

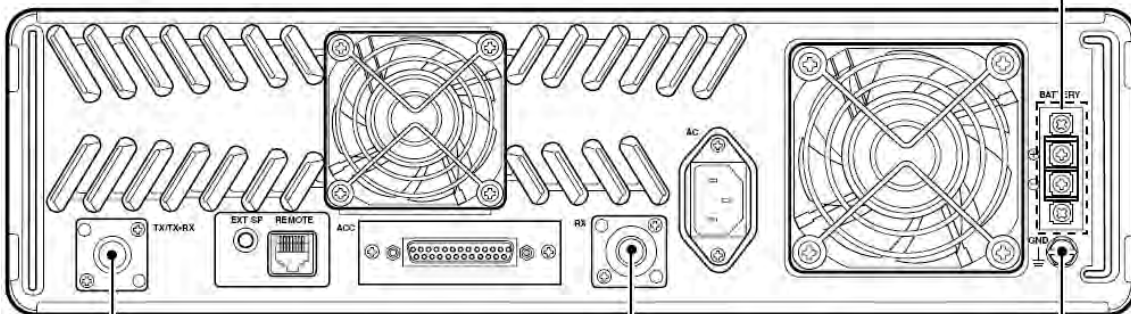

[TX(TX•RX) ANT] (p. 5)



TX•RX antenna required for installing an internal duplexer.

[RX ANT] (p. 5)



GROUND (p. 5)

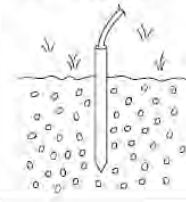

Advanced connections

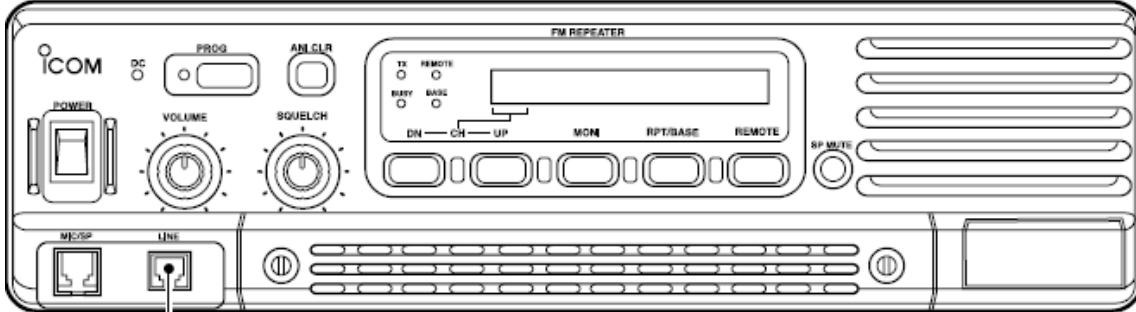

LINE CONNECTOR (Front panel view)

- ① NC (No connection)
- ② L1 input/output
- ③ L2 input/output
- ④ NC (No connection)

*This illustration is an example only.
Telephone connector type is different for some countries.

EXTERNAL SPEAKER

Use a 4 Ω speaker.

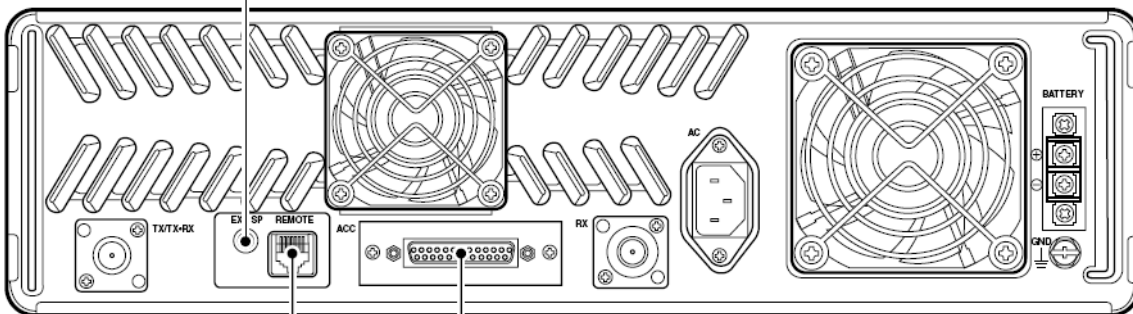

[REMOTE] (p. 3)
Used for external equipment control.

ACC CONNECTOR (pgs. 3, 4)
Used for external equipment control.

❑ Power

Make sure the [POWER] switch is turned OFF when connecting an AC power cable and a backup battery (emergency power supply).

The IC-FR3000/FR4000 series can operate with an AC or DC power supply. If AC power is interrupted when operating the repeater with an AC power supply, power is automatically provided to the [BATTERY] terminals.

NOTE: When repeat to turn the repeater ON and OFF quickly, the repeater may not turn ON. In this case turn OFF the power switch and wait for a while, then turning power ON again.

➤ In AC operation

- The [DC] indicator turns OFF.
- Use the supplied AC power cable for connection to a domestic AC outlet.
- Extension cords should not be used unless absolutely necessary. Using improper extension cords could result in fire risk.
- Usually the battery is continuously charged with a small amount of current from an AC power supply through the regulator circuit in the repeater. Discharging is therefore prevented even if the battery is not used for a long time.

➤ In DC operation

CAUTION: Voltages greater than 16 V DC will damage the repeater. Check the source voltage before connecting the power cable.

- The [DC] indicator lights up green.
- **DO NOT** place the backup battery on or near the repeater. Lead-acid batteries should be placed at least 5 m (16.4 ft.) away from the repeater. Use a heavy duty cable to make the connection and be sure both the positive (red) and negative (black) terminals are correctly connected.
- When connecting to the battery, keep in order to connect the DC power cable to the repeater first, then the positive (red) terminal and negative (black) terminal to the battery to prevent an electric shock.
- After the battery is connected and the [POWER] switch is ON, the repeater continuously supplies approx. 1 A for charging the battery. If the repeater stops functioning while connected to the battery, disconnect the battery, recharge it, then connect the battery to continue operation after the battery is charged. During repeater transmission, approx. 17 A of battery power is consumed.

❑ Mounting the repeater

➤ Using the optional MB-78

An optional MB-78 19 INCH RACK MOUNT BRACKET is available for mounting the repeater into a 19 inch rack. The MB-78 can install the repeater's bottom side and top side.

• Bottom side installation

- ① Remove the 2 screws (M4 × 8) from both side of the side panel (front-end).

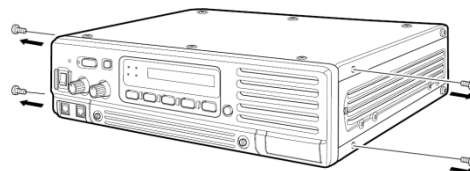

- ② Attach the MB-78 to the bottom side of the repeater.

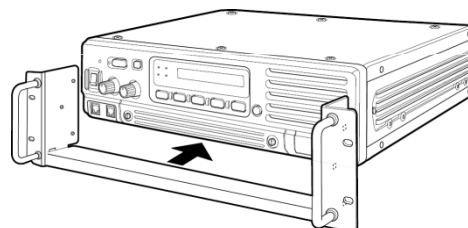

- ③ Tighten the 1 supplied screws (M4 × 8) and 2 removed screws to each side. (6 screws at total)

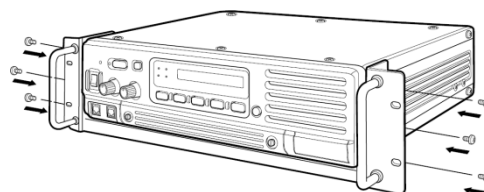

- ④ The completed bottom side installation should look like below

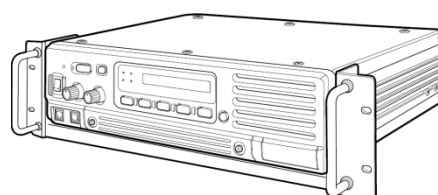

• **Top side installation**

① Remove the 1 screw (M4 × 8) from both side of the MB-78.

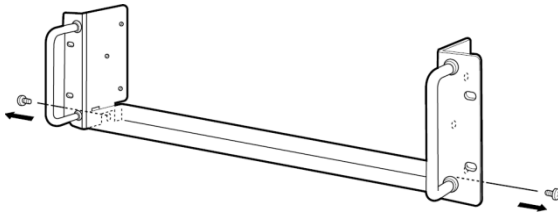

② Remove the handles from bottom bar. And turn the handles upside down, then replace the handles right side and left side.

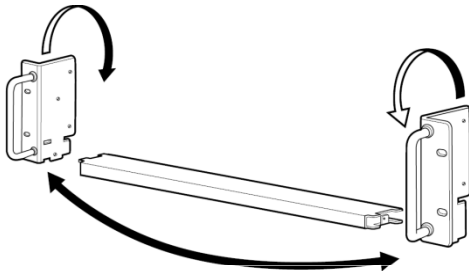

③ Attach the handles to the bar, then tighten the screws.

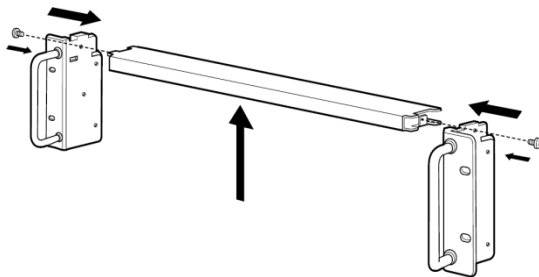

④ The completed MB-78 should look like below

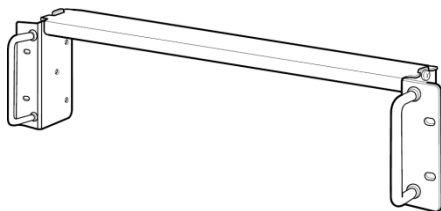

⑤ Remove the 2 screws (M4 × 8) from both side of the side panel (front-end).

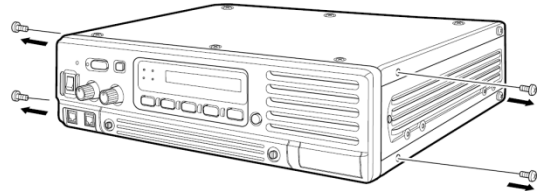

⑥ Attach the MB-78 to the top side of the repeater. Then tighten the 1 supplied screws (M4 × 8) and 2 removed screws to each side. (6 screws at total)

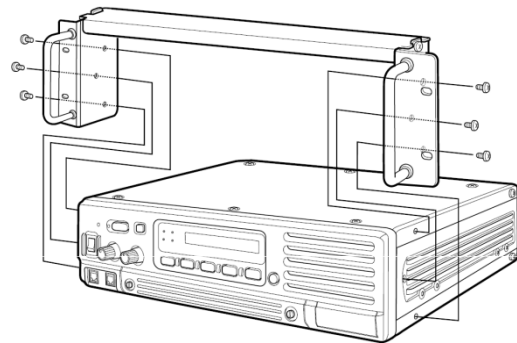

⑦ The top side installation should look like below.

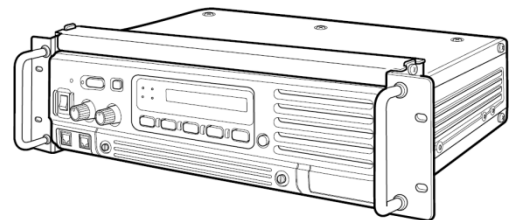

⑧ Turn the repeater upside down, then removing the 4 legs for mounting the 19 inch rack.

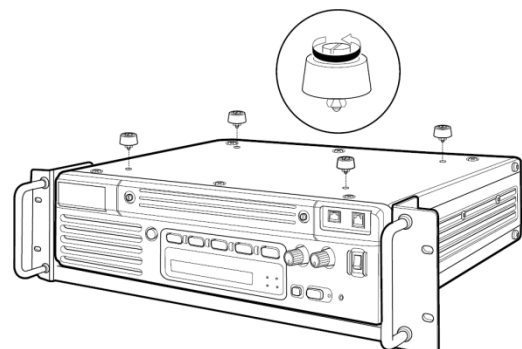

➤ **Using the optional MB-77**

An optional MB-77 WALL MOUNT BRACKET is available for mounting the repeater to a flat surface.

⚠ WARNING: NEVER mount the repeater on the MB-77 by yourself. At least two people are required to mount the repeater since it weights approx. 12 kg (26 lb).

- Mount the MB-77 securely with the 12 supplied screws (M6 × 30) to a surface which is more than 50 mm thick and can support more than 20 kg. The unit must be mounted on a flat hard surface only.

- ① Attach the hinges at right side of the repeater as shown below.
- ② Tighten the 2 supplied screws (M5 × 12) for each.

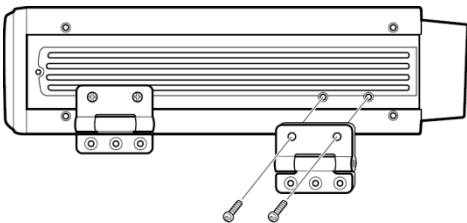

- ③ Put the MB-77 on the wall (or wherever you plan to mount the repeater).
- ④ Tighten the 12 supplied screws (M6 × 30) using flat washers and spring washers.

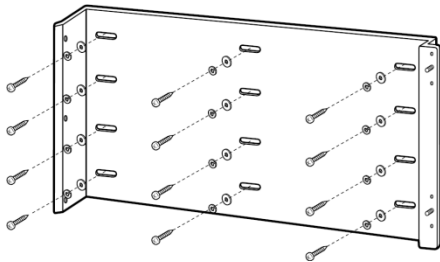

NOTE: Put this way to repeater's front panel will be bottom side.

- ⑤ Attach the hinges with repeater to MB-77 and tighten the 4 supplied screws (M5 × 10) and 2 nuts (with spring washer).

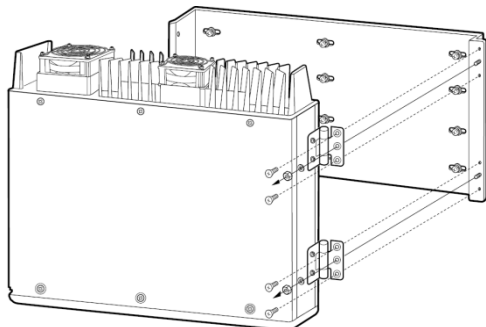

- ⑥ Tighten the 3 supplied screws (M5 × 12) to other side.

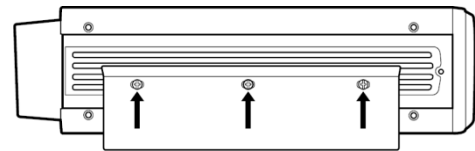

• **For setting up the repeater with MB-77**

- ① Remove the 3 screws (M5 × 12) at left side of the MB-77 when repeater's front panel is bottom side.
- ② Pull the left side of the repeater.
- ③ Remove the screws and open the bottom cover or top cover of the repeater, then set the repeater up.
- ④ Return the top or bottom cover of the repeater and MB-77 to their original positions.

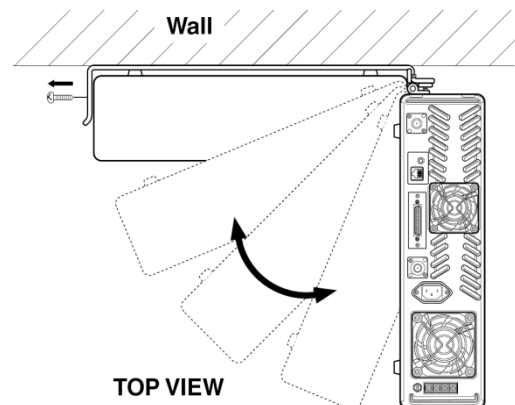
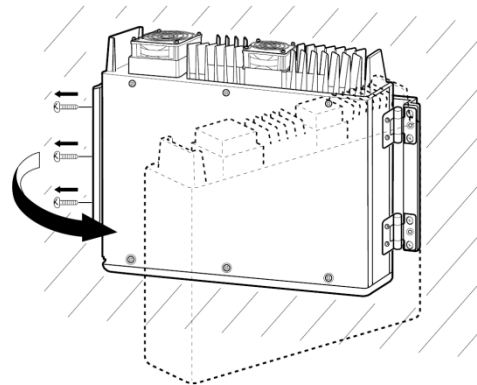

❑ Opening the repeater's case

Follow the case and cover opening procedures shown here when an optional unit is installed or adjust the internal units, etc.

CAUTION: DISCONNECT the AC power cable and/or DC power cable from the repeater. Otherwise, there is danger of electric shock and/or equipment damage.

- ① Remove 6 screws from the top of the repeater and 4 screws from the sides, then lift up the top cover.
- ② Turn the repeater upside down.
- ③ Remove 6 screws from the bottom of the repeater, and 4 screws from the sides, then lift up the bottom cover.

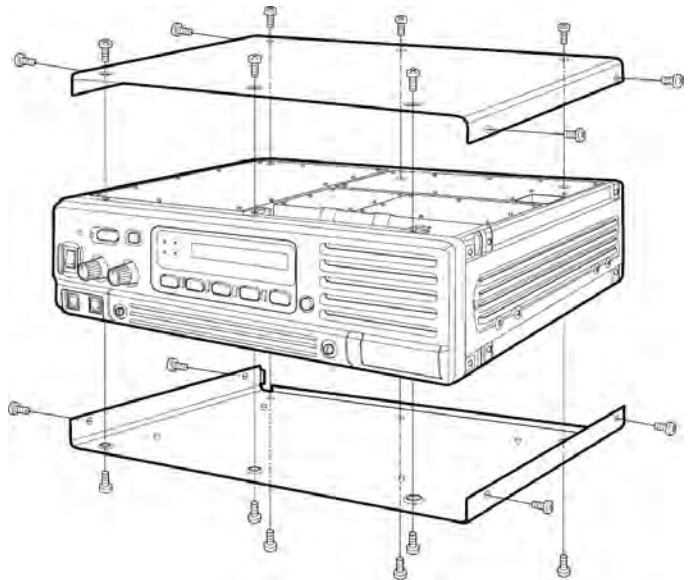

❑ Voice scrambler unit installation

The UT-109 (#01)/UT-110 (#01) provides high performance private communication for base operating mode. In order to receive or send scrambled transmissions, the UT-109 (#01)/UT-110 (#01) must be installed and to activate the scrambler function.

- ① Remove the top and bottom covers as shown above.
- ② Remove 8 screws from the LOGIC shielding plate, then remove the plate.

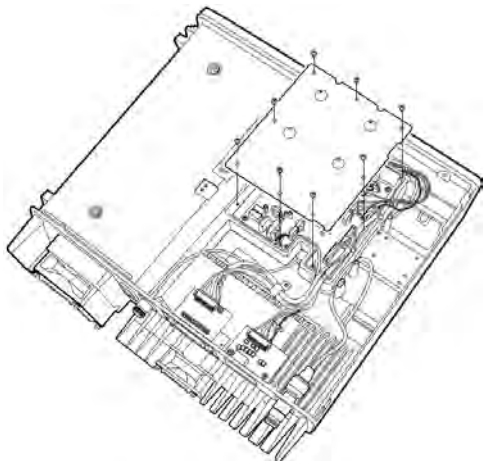

- ③ Cut the pattern on the PCB at the RX AF circuit (CP1) and TX mic circuit (CP2) on the LOGIC unit as shown at right.

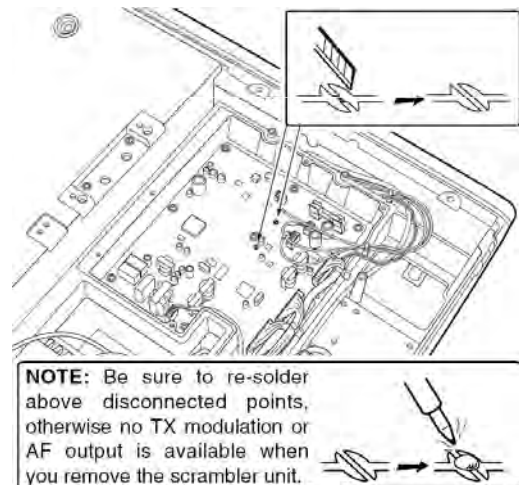

- ④ Turn the repeater upside down, then install the scrambler unit as shown below.

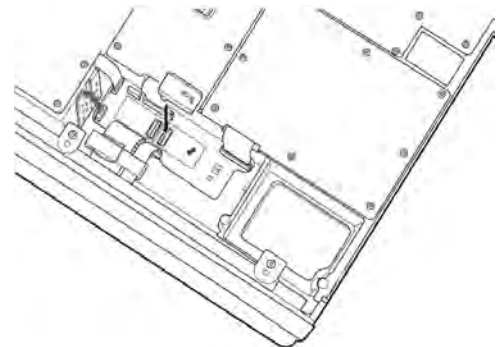

- ⑤ Return the LOGIC shielding plate, top and bottom covers to their original positions.

3-1-6 Duplexer and Isolator Installation (Reference only)

NOTE: The instruction below is just for your reference. The size of the duplexer and/or the isolator depends on what model you will choose for the system, therefore screw holes may not match as described below.

□ Duplexer And Isolator Installation

- ① Remove the top and bottom covers. (See page 23)
- ② Tighten 4 screws, **(A)**, for installing the duplexer unit.
- ③ Tighten 4 screws, **(B)**, for installing the isolator unit.

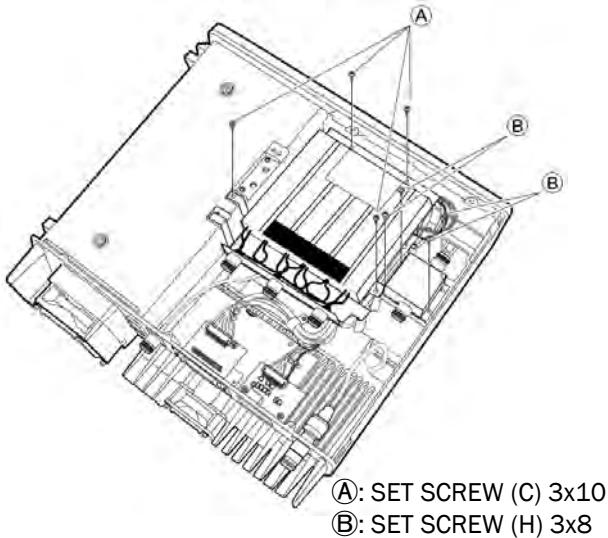

BOTTOM VIEW OF THE REPEATER

- ④ Cut the RX ANT-RX unit cable and then modify it.
- ⑤ Connect the modified cable to the duplexer unit (RX frequency connector).

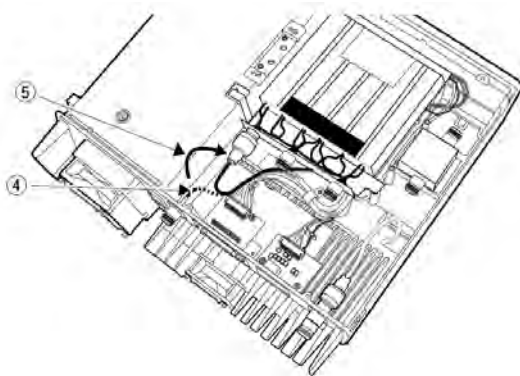

BOTTOM VIEW OF THE REPEATER

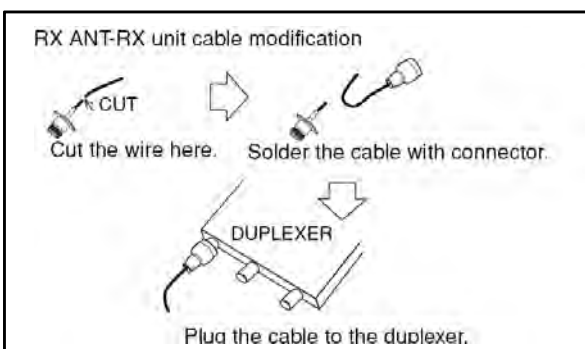

- ⑥ Unplug the TX ANT-PA unit cable from the TX ANT connector (CHASSIS), and then plug to the isolator (input connector).

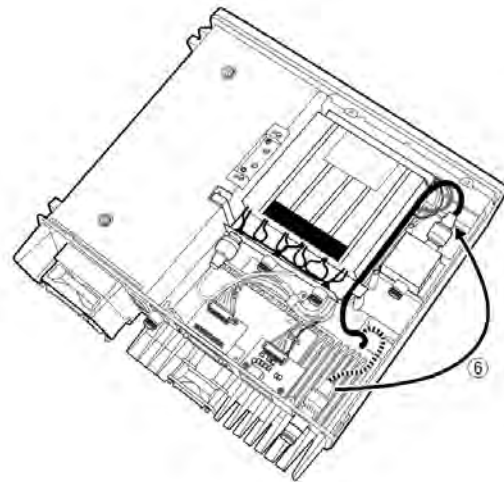

BOTTOM VIEW OF THE REPEATER

- ⑦ Connect the *cable between the isolator (output connector) and the duplexer (TX frequency connector).
- ⑧ Connect the *cable between the duplexer (ANT connector) and the TX ANT connector (CHASSIS).
- ⑨ Return the top and bottom cover to their original position.

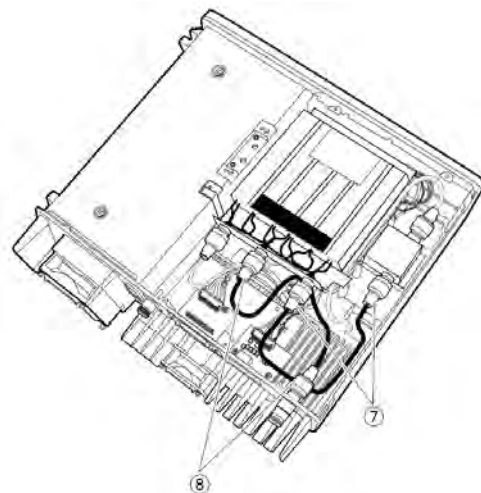

BOTTOM VIEW OF THE REPEATER

***NOTE:** Connection cables are not supplied with the isolator and duplexer. Therefore, you will need to make them by yourself.

Duplexer and Isolator Installation (Reference only)

□ Connection

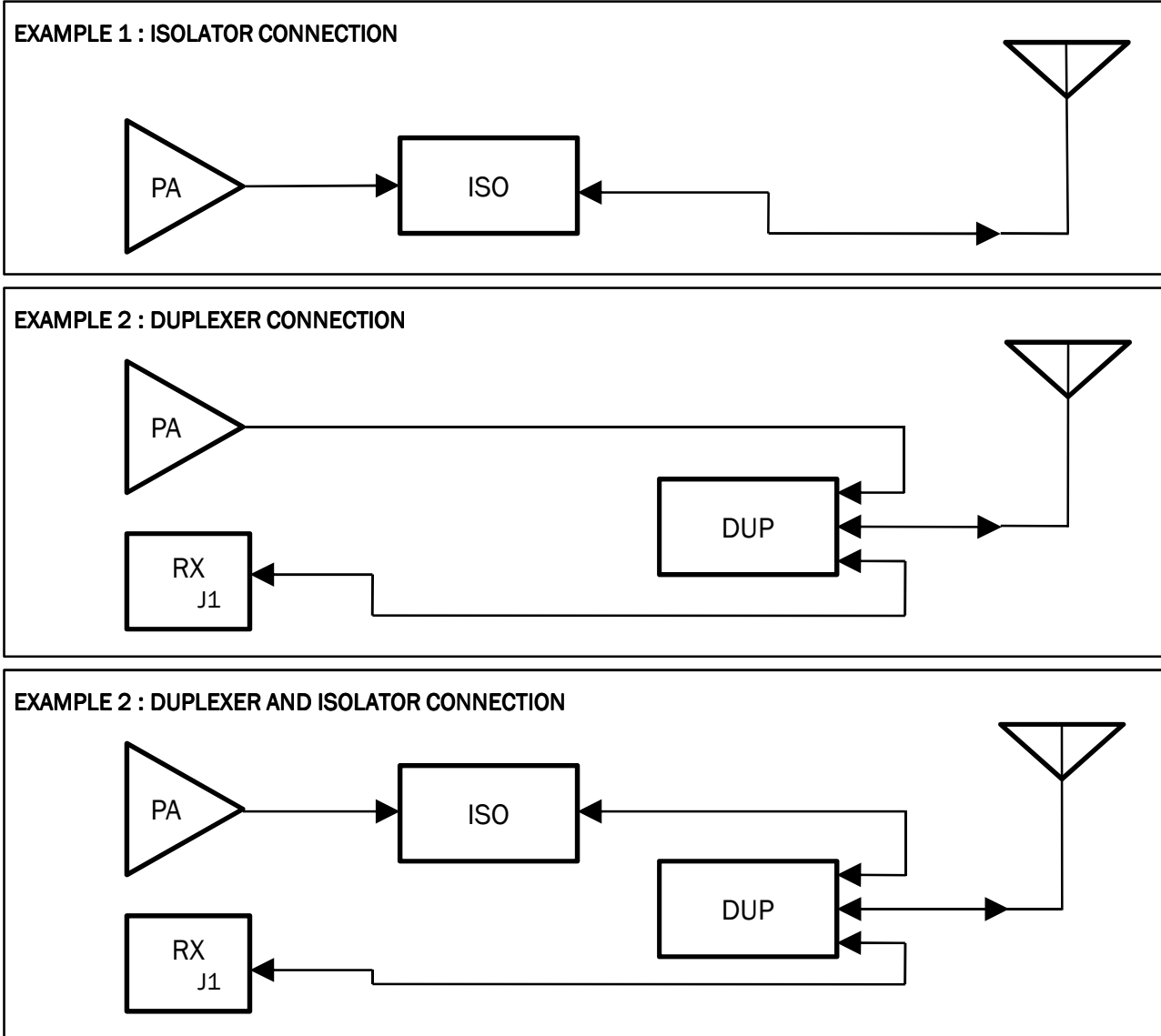

ISO : ISOLATOR DUP : DUPLEXER

What is a Duplexer?

A duplexer is what allows the antenna to be shared between transmit and receive.

What is a Circulator/Isolator?

A Circulator is a 3-port ferrite device used to route microwave signals from one port to another, Port 1-> Port 2, Port 2 -> Port 3, Port 3 -> Port 1.

An Isolator is basically a circulator with port 3 terminated. It becomes a 2 port device which transmits a signal in port 1 and out port 2. Any reflected energy or any signal entering port 2 will be routed to port 3 where it is absorbed. Thus port 1 is "isolated" from port 2.

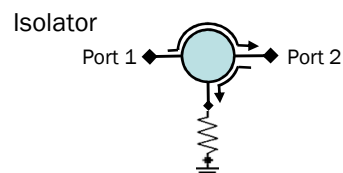
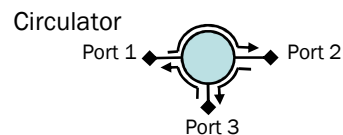

Duplexer and Isolator Installation (Reference only)

The sample list of Duplexers and Isolators available in the market

➤ Duplexers

PROCOM (www.procom-dk.com)

Band	Model No.	Descriptions
VHF	MPX2/6LN-4/6	Frequency range 138-156MHz, duplex spacing range 4-6MHz
	MPX2/6LN-6/15	Frequency range 138-156MHz, duplex spacing range 6-16MHz
	MPX2/6HN-4/6	Frequency range 152-175MHz, duplex spacing range 4-6MHz
	MPX2/6HN-6/15	Frequency range 152-175MHz, duplex spacing range 6-16MHz
UHF	MPX70/6LN-5/7	Frequency range 406-440MHz, duplex spacing range 5-7MHz
	MPX70/6LN-7/9	Frequency range 406-440MHz, duplex spacing range 7-9MHz
	MPX70/6LN-9/13	Frequency range 406-440MHz, duplex spacing range 9-13MHz
	MPX70/6LN-13/16	Frequency range 406-440MHz, duplex spacing range 13-16MHz
	MPX70/6HN-5/7	Frequency range 430-470MHz, duplex spacing range 5-7MHz
	MPX70/6HN-7/9	Frequency range 430-470MHz, duplex spacing range 7-9MHz
	MPX70/6HN-9/13	Frequency range 430-470MHz, duplex spacing range 9-13MHz
	MPX70/6HN-13/16	Frequency range 430-470MHz, duplex spacing range 13-16MHz

Radio Frequency Systems (www.rfsworld.com)

Band	Model No.	Descriptions
VHF	636-6A-1-2	Frequency range 144-154MHz, duplex spacing range 4.5MHz
	636-6A-2-2	Frequency range 154-164MHz, duplex spacing range 4.5MHz
	636-6A-3-2	Frequency range 164-174MHz, duplex spacing range 4.5MHz
UHF	633-6A-1N	Frequency range 406-450MHz, duplex spacing range 5MHz
	633-6A-2N	Frequency range 450-470MHz, duplex spacing range 5MHz
	633-6A-5N	Frequency range 406-450MHz, duplex spacing range 10MHz
	633-6A-6N	Frequency range 450-470MHz, duplex spacing range 10MHz
	633-6A-7N	Frequency range 470-512MHz, duplex spacing range 10MHz
	633-6A-8N	Frequency range 355-406MHz, duplex spacing range 10MHz
	633-6A-9N	Frequency range 470-512MHz, duplex spacing range 3MHz

➤ Isolators

Sinclair (www.sinclairtechnologies.com)

Band	Model No.	Descriptions
VHF	I2113A	132-174MHz, 60 watt load, 125 watt input power, factory-tuned
	I2113T	138-174MHz, 60 watt load, 125 watt input power, Field Tunable
UHF	I3113A	406-512MHz, 60 watt load, 125 watt input power, factory-tuned
	I3113AT	406-430MHz, 60 watt load, 125 watt input power, Field Tunable
	I3113AT	450-470MHz, 60 watt load, 125 watt input power, Field Tunable

PROCOM (www.procom-dk.com)

Band	Model No.	Descriptions
VHF	PRO-IS-150-S	145-175MHz, 150 watt input power, Field Tunable
UHF	PRO-IS-450-S	400-470MHz, 125 watt input power, Field Tunable



3-2 Cloning Software CS-FR3000

3-2-1 Basic Setup of Cloning Software

□ Getting started

- This cloning software is designed to perform data setting and cloning for the IC-FR3000/IC-FR4000 series VHF/UHF FM REPEATERS.
- HELP WINDOW: CS-FR3000 has a help window to describe functions and operation.

□ System requirements

To use this program, the following hardware and software are required:

PC

- Microsoft® Windows® 98/98SE/Me/2000/XP is installed
- With RS-232C serial port (D-sub 9-pin) port

Other item

Optional OPC-478 CLONING CABLE and OPC-592 ADAPTOR CABLE

□ Software installation

1. Quit all applications when Windows is running.
2. Insert the CD into the appropriate CD drive.
3. Double-click the "Setup.exe" contained in the CD.
4. The "Welcome to the InstallShield Wizard for CS-F5060" will appear as below. Click [Next>].



5. The "User Information" will appear as below, then type your name, your company name and the product ID number with the following manner. Then click [Next >].
 - ID number: 244301-(6 digit serial number)
 - e.g. the serial number on the CD is 001001, enter "244301-001001" as the ID number.

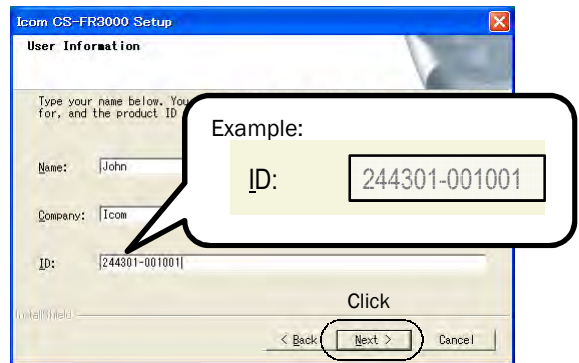

6. The "Choose Destination Location" will appear as below. Then click [Next>] to install the software to the destination folder. (e.g. C:\Program Files\Icom\CS-FR3000)
 - Click [Browse...] to select another destination folder before clicking [Next >], if desired.

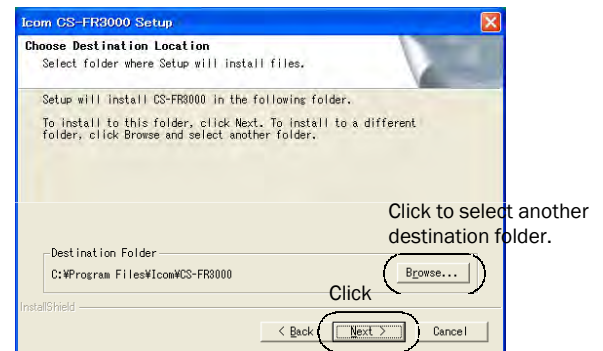

7. After the installation is completed, the "InstallShield Wizard Complete" will appear as below. Then click [Finish].

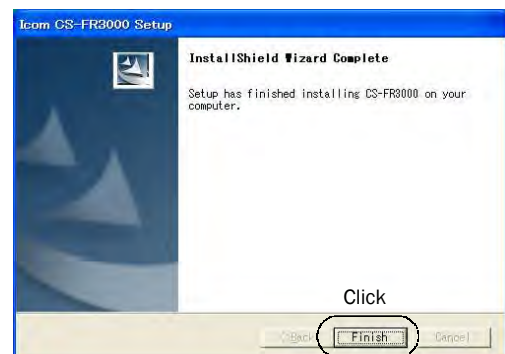

8. Eject the CD.
9. Program group 'CS-FR3000' appears in the 'Programs' folder of the start menu, and 'CS-FR3000' short cut icon appears on the desktop screen.

Note 1: Icom distributes cloning software by CD or license. Depending on this, some information here may not apply as written, e.g. ID number.

Note 2: Please see other documents provided by Icom regarding to Microsoft® Windows Vista™.

□ Connections

All cloning operations are performed from the computer's mouse or keyboard—the operation required on the receiver side is; Turning power ON the repeater.

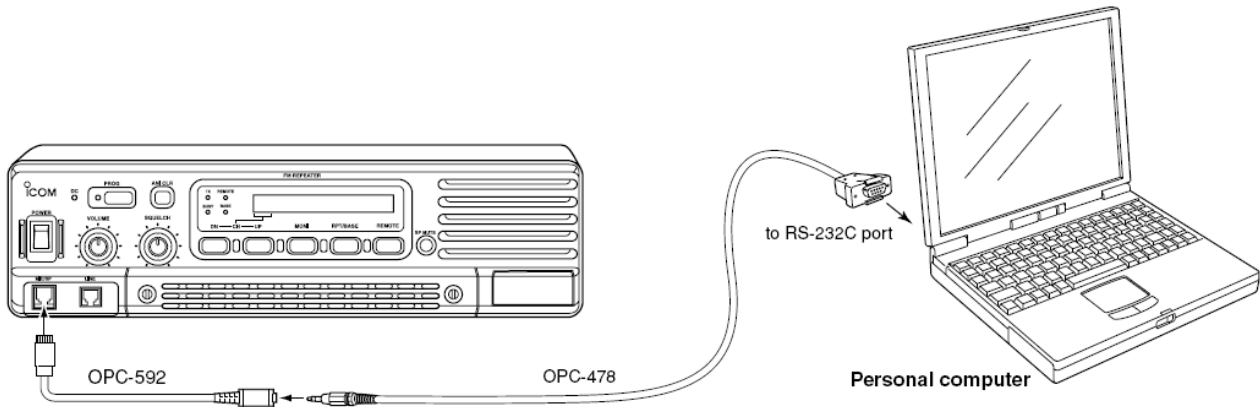

□ Screen description

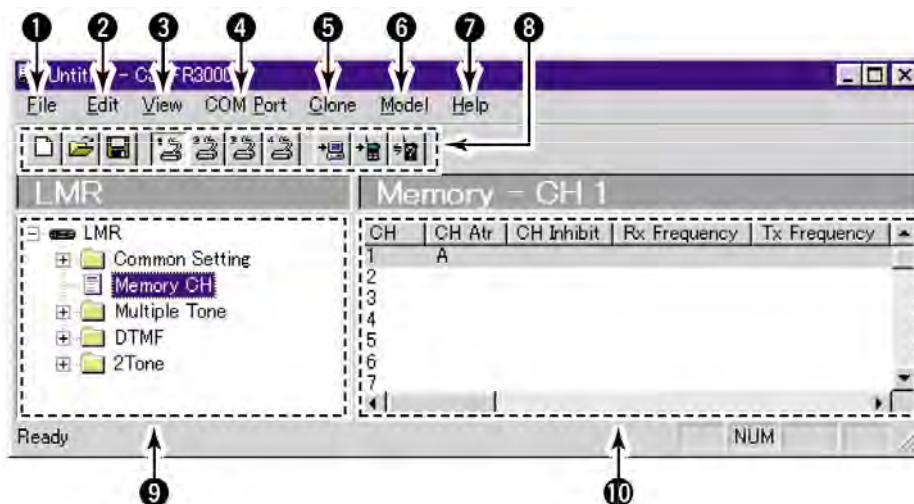

❶ FILE MENU [File]

Used for saving memory channel contents, printing the pre-programmed information or quitting the program, etc.

❷ EDIT MENU [Edit]

Edits each memory channel information (Prio A, Emergency, Emergency OFF, etc.) via the Edit menu.

❸ VIEW MENU [View]

Turn the Toolbar/Status bar ON or OFF.

❹ COM PORT MENU [COM Port]

Selects the COM port

NOTE: 'Communication failed' dialog box appears when the COM port is not set correctly.

❺ CLONING MENU [Clone]

Click to display cloning menu and cloning information dialog box.

❻ MODEL MENU [Model]

Click to select the proper model type from LMR (2Tone) or PMR (5Tone).

❼ HELP MENU [Help]

Click to display help contents and cloning software revision information.

❽ TOOLBAR

Shortcut key appears on the toolbar when clicking the toolbar function in the [View] menu.

❾ TREE VIEW SCREEN

Click the folder icon which you want to edit.

❿ MEMORY CH SCREEN

Display the Memory CH (channel or editable item) information.

Basic Setup of Cloning Software

□ Programming information

- We recommend that you should read out all the repeater's data before start entering/editing parameters even if the repeater is factory fresh. This avoids rare glitches which might cause programming errors when writing back the altered parameters.
- CS-FR3000 has 2 model types. You can select the desired model type which you are going to clone. LMR (2Tone) or PMR (5Tone) is available. The Tree View screen content will be changed when the model type is switched.

LMR

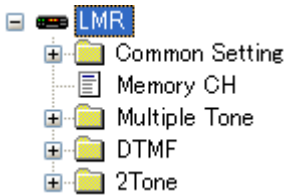

PMR

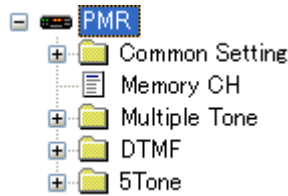

- Select the model type which you are going to clone from; LMR (2Tone) and PMR (5Tone).

🔔 NOTE:

The model type must be selected at first, otherwise the edited contents will be lost.

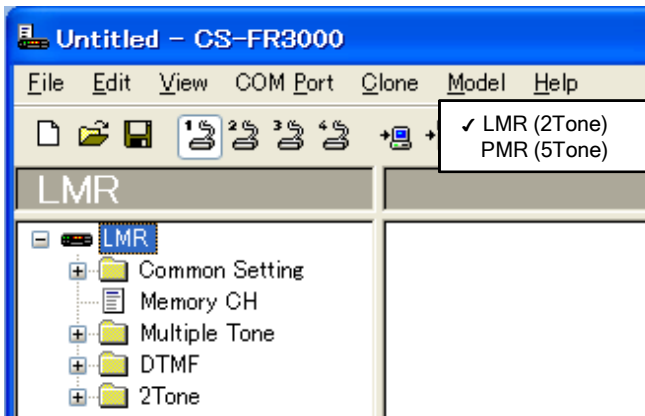

- Double-click on the desired memory channel, or right-click the cell then click **[Edit Memory ...]** to enter the memory channel program screen.

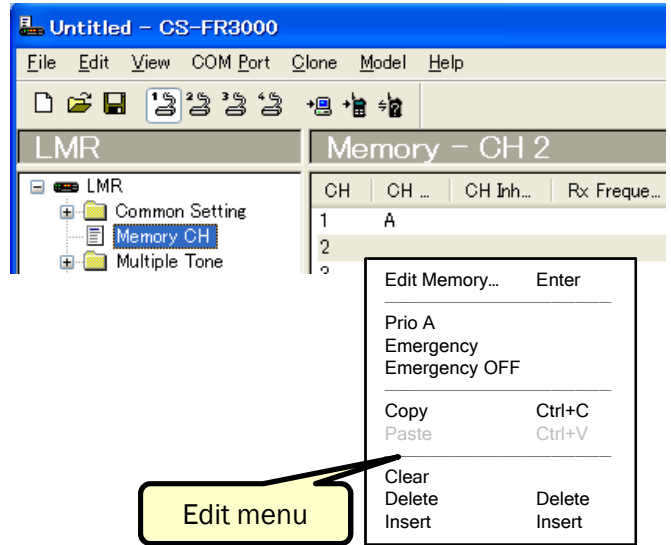

Memory channel program screen

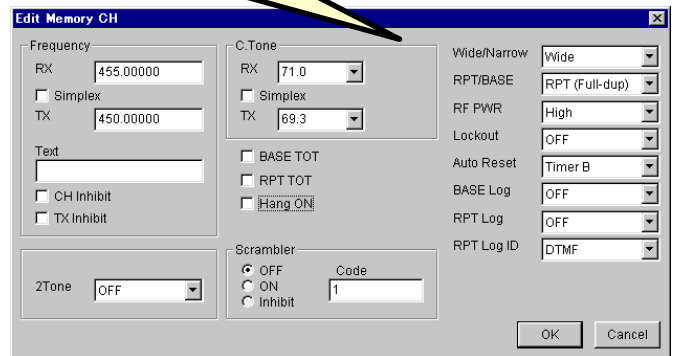



3-2-2 Cloning Items

☐ Cloning items

Common Setting

➤ Key & Display

Set Prio A, Prio A (Rewrite), Disp Select, Lock, High/Low, etc. for the programmable key assign, and set Opening text, RF Power Selection, MR/Code Display (PMR) and Beep condition for the display assign.

➤ Common

Commonly set items such as Clone Comment (1)/(2), User Password, PWR ON Password in the Common 1 screen, Auto Reset Timer A/B, Scrambler Type, Group Code in the Common 2 screen, RPT TOT Timer, Penalty Timer, Hang ON Timer in the Common 3 screen.

➤ Expert

Expertly set item such as TX/RX inverse, the Low/High beep tone frequencies in the Expert 1 screen, REG Unit TEMP, PA Unit TEMP, TEL Code, TEL Code Times, Backup condition in the Expert 2 screen.

Memory CH

The 'Memory CH' window allow you to edit the channel information. Editable items such as RX/TX Frequency, Text, RX/TX C.Tone, BASE/RPT TOT, Hang ON, Wide/Narrow, RPT/BASE, RF PWR, Lockout, Auto Reset, BASE/RPT Log, Scrambler OFF/ON/Inhibit, Scrambler Code.

Multiple Tone

Set a continuous tone frequency for RX or TX mode or check the Simplex's check-box to use the same tone frequency as TX mode to RX mode.

DTMF

➤ RX Code CH

Program DTMF code of up to 24 digits, Text, LCD Blink, Beep, SP Mute and Code MR conditions.

➤ TX Code CH (Autodial)

Program DTMF code of up to 24 digits.

➤ RX System Code

Program DTMF code of 4 digits in the System Password, System Control Exit, Repeat Start/Stop, TX Start/Stop, etc.

➤ TX System Code

Program DTMF code for response of 4 digits in the System Password OK ACK, System control Exit ACK, OK ACK, and NG ACK.

➤ DTMF Setting

Set DTMF Timer, 1st Timer, Header Tone, De-limiter Tone, etc.

2Tone

➤ RX Code CH

Set 1st/2nd tone frequencies, Group Call, text, ANS, Beep, Auto TX and Stun.

➤ RX Code Setting

Set Notone Timer, Group Timer and Auto TX Timer.

➤ TX Code

Set Code type, 1st/2nd tone Frequency and Period.

5Tone

➤ RX Code CH

Set RX Code, text, ABC, Aud Mode, Emer, Beep, ext.

➤ RX Code Setting

Set Link A Timer, Compare Digit, ID Decode Timer and Auto Timer.

➤ TX Code CH

Set TX Code, Text, Input Digit, Update, ABC condition, and Sel.

➤ TX Code Setting

Set Long Tone Timer, Link R/1/2 Timer, Lead Out Delay Timer, ABC Decode Timer, etc.

➤ Format

Set the Tone Period for a tone encoder, Notone Timer and Tone Length.

➤ User Tone

set the encode tone frequency, the lower and higher edge of the tone decode frequency range. And check the 'Auto' check-box to recommended decode frequencies are automatically set.

NOTE: The above instructions are for reference only. Please refer to the HELP file of the cloning software for the function or setting details.



3-3 Operation

□ Turning power ON

- ① Push [POWER] to turn power ON.
- ② If the repeater is programmed for a power on password by an Icom Dealer, input digit codes directly.
 - The keys in the table below can be used for password input.
 - The repeater detects numbers in the same block as identical. Therefore “01234” and “56789” are the same.

KEY	[DN]	[UP]	[MONI]	[RPT/BASE]	[REMOTE]
NUMBER	0 5	1 6	2 7	3 8	4 9

- ③ When the “PASSWORD” indication does not clear after inputting 4 digits, the input code number may be incorrect. Turn power off and start over in this case.

□ Receiving and transmitting

➤ Receiving

- ① Push [POWER] to turn power ON.
- ② Set the audio and squelch levels.
 - ➔ Rotate [SQUELCH] fully counterclockwise in advance.
 - ➔ Rotate [VOLUME] to adjust the audio output level.
 - ➔ Rotate [SQUELCH] clockwise until the noise disappears.
- ③ Push [UP] or [DN] to select the desired channel.
 - When receiving a signal, BUSY indicator turns ON and audio is emitted from the speaker.
 - Further adjustment of [VOLUME] to a comfortable listening level may be necessary at this point.

➤ Transmitting

- ① Take the microphone off hook.
- ② Wait for the channel to become clear.
- ③ Push and hold [PTT] to transmit, then speak into the microphone at your normal voice level.
- ④ Release [PTT] to receive.

IMPORTANT:

To maximize the readability of the transmitted signal:

- (1) Pause briefly after pushing [PTT].
- (2) Hold the microphone 1 to 2 inch (2.5 to 5 cm) from your mouth, then speak into the microphone at a normal voice level.

Backup Repeater System

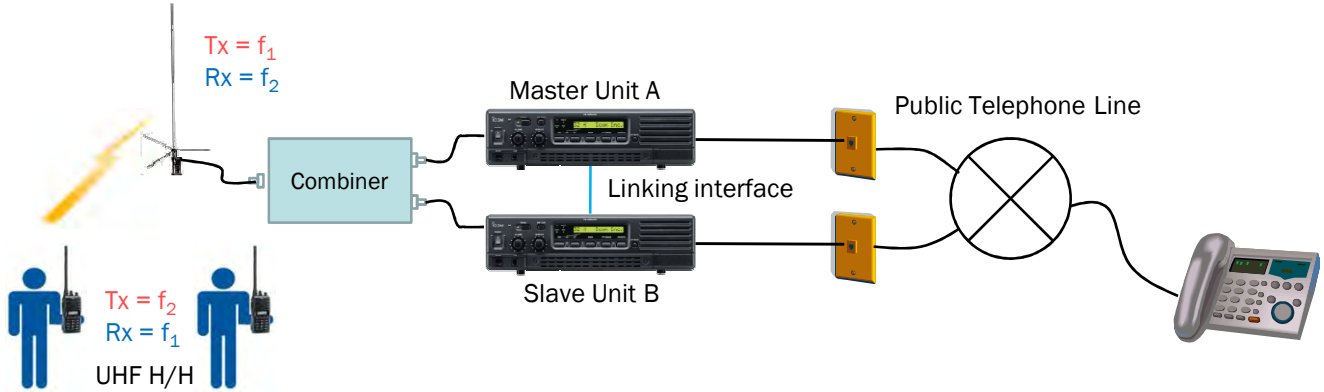

- This is a backup plan when Master unit A is in the Alert condition (unlock etc.), Master unit A automatically makes a phone call and outputs the Alert Code the designated number of times. After that, Master unit A becomes the slave unit, and Slave unit B becomes the master unit.

System requirement (One site)

Descriptions	Model Number	Quantity
UHF Repeater	IC-FR4000	
UHF Antenna		
Duplexer		
Combiner		
Interface Cable	25p to 25p	

➤ Backup function (Programming example)

DTMF: Tx Code Ch. (Autodial) setting

- Input the phone number of the station to be called during an Alert, in the Alert column.

CH	Code
1	0356008686111#
2	0356008676222#
3	0356008686333#
4	0356008686444#
5	0356008686555#
6	
7	
8	
9	
10	
11	
12	
13	
14	
15	
16	
17	
18	
19	
Alert	0356008686111#

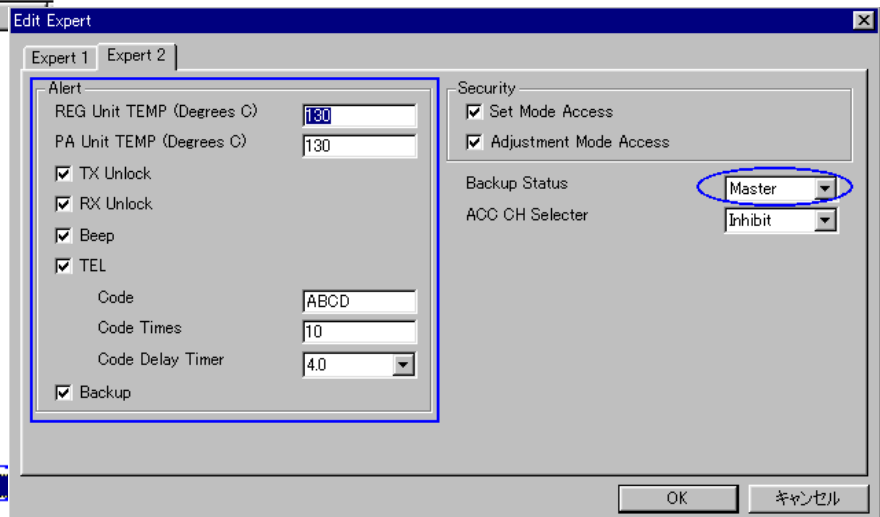

Connection example

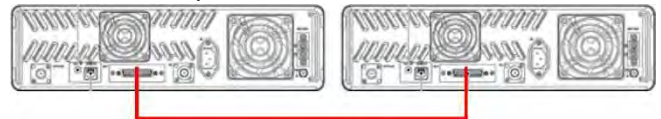

Connect two repeaters by interface cable (25p to 25p).

These interface cables are not sold as Icom accessories, therefore please assemble the interface cable by yourself. The connection diagram is as follows;

Repeater (25pin)		Repeater (25pin)
Pin 3 (M/S IN)	↔	Pin 15 (MS OUT)
Pin 15 (MS OUT)	↔	Pin 3 (M/S IN)
Pin 21-24 (GND)	↔	Pin 21-24 (GND)

Common Setting) Expert2 setting

- Check the TEL item
Alert Telephone CALL is enabled.
- Check the Backup item
Master/Slave switchover is enabled.

3-5 Multi-tone Function

Multi-tone function

The IC-FR3000/FR4000 allow relaying between multiple groups with one repeater. (When group separation is carried out with a continuous tone)

This feature can be used in both LMR and PMR mode.

- Optional 16 Tx/Rx continuous tones can be set for each of the 32 channels.
- The Tx and RX tone can be set independently. (CTCSS/DTCS) E.g. Rx (88.5 Hz) / Tx (223)
- The DTCS inverse code can be selected. (Normal / Inverse)

Operation

- The continuous tone is set for each group.
- When Group A is using the repeater, the other groups cannot use it.
- When the Group A relay is finished, the other groups can then use the repeater.

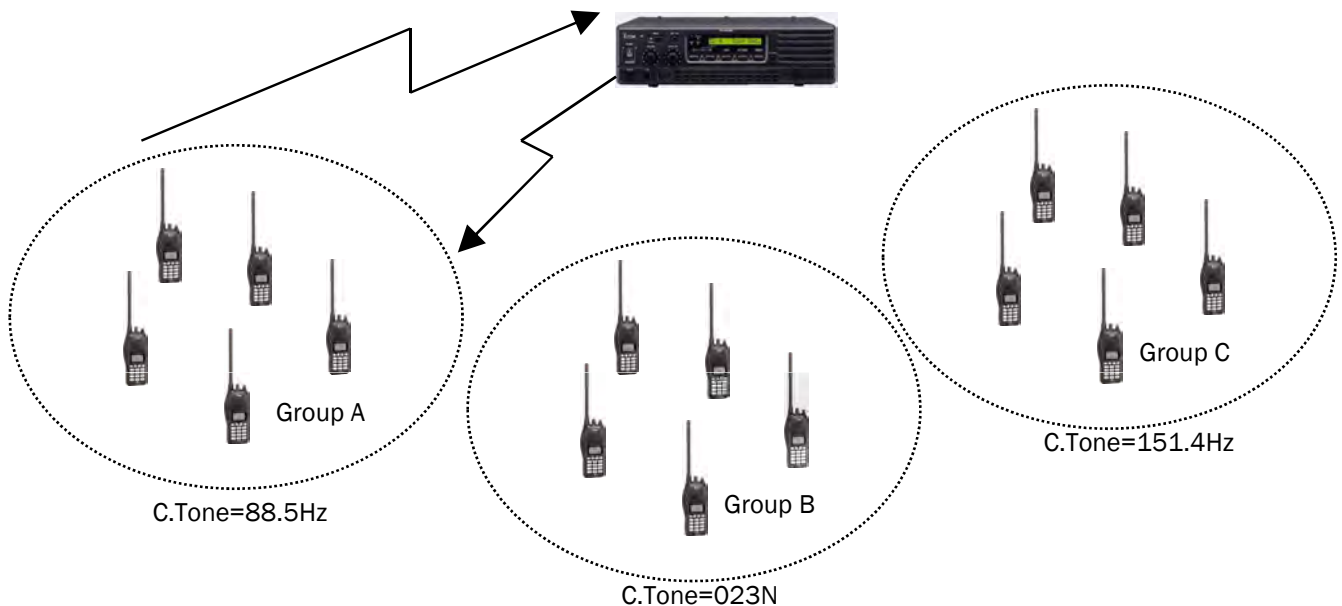

Multi-tone function (Programming example)

Memory Ch. setting

- Set the C.Tone to "Multi".

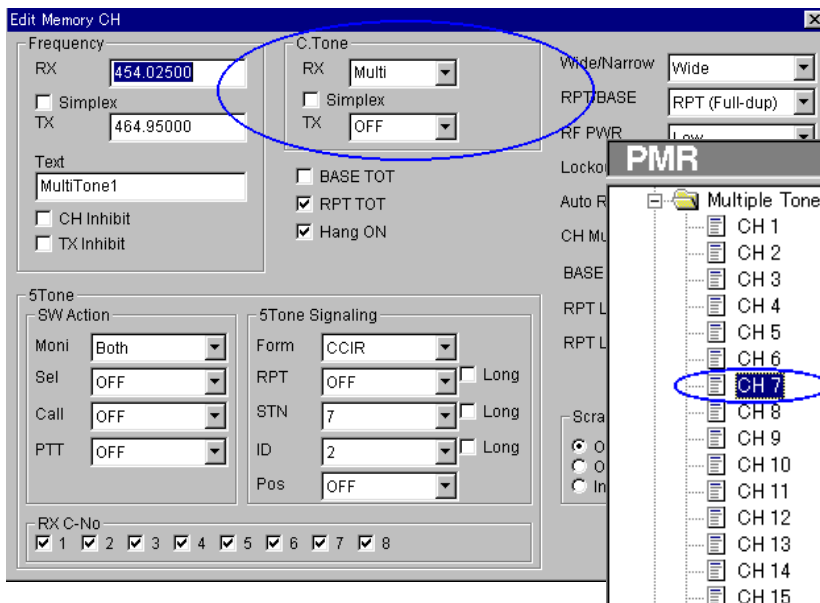

Multiple Tone setting

- Select a Memory channel.
- Set an optional C.Tone for Tx/Rx respectively.

PMR		Multiple Tone:CH 7 - No. 1		
No.	RX	TX		
1	88.5	223N		
2	251N	<----		
3	OFF	<----		
4	151.4	<----		
5	OFF	<----		
6	82.5	<----		
7	OFF	<----		
8	026N	<----		
9	023N	<----		
10	023i	<----		
11	233.6	<----		
12	OFF	<----		
13	465N	<----		
14	OFF	<----		
15	OFF	<----		
16	411N	<----		



3-6 Remote Control Function

3-6-1 Remote Control Setting

☐ Phone Line to Repeater Connection

Phone Line to Repeater Connection for Remote Control Function

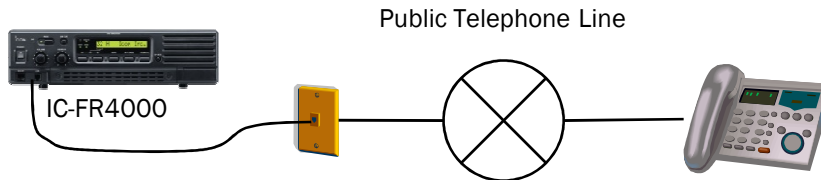

1-1 REMOTE CONTROL SETTING

➤ System control

To enable remote control functions, the DTMF settings (RX System Code, TX System Code, DTMF Setting, TX Code CH (Autodial), etc.) must be pre-programmed using CS-FR3000 cloning software. Use CS-FR3000 help screens for description of functions and operation and for programming details.

☞ **NOTE:** Check the “Control” check-box to enable remote control operation using DTMF signals

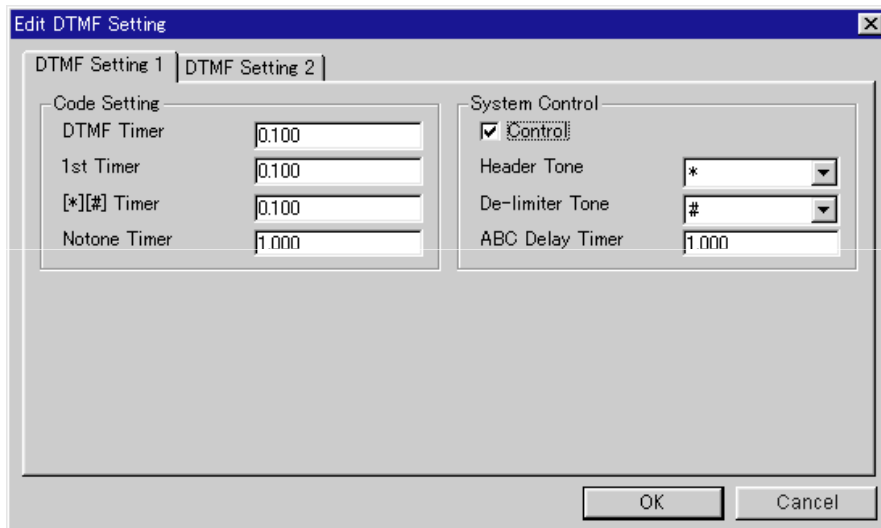

☞ **NOTE:** Check the “TEL Function” check-box to enable remote control operation using DTMF signals from the telephone line.

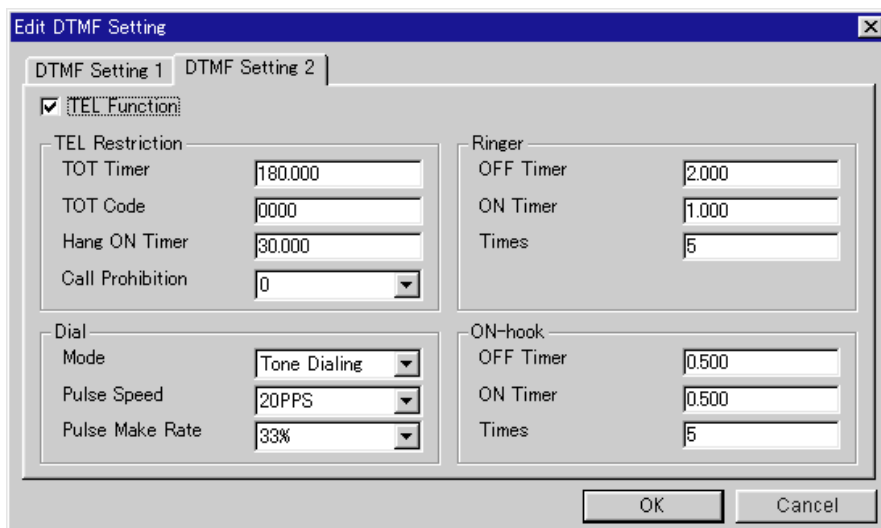



3-6-2 Remote Control Operation

1-2 REMOTE CONTROL OPERATION

➤ System control command

NOTE: All commands must be entered within 10 sec. of entering a password. It is possible to enter the password and command continuously.

Format of Command

• Basic command code

The Basic command code consists of a fixed 4-digit command code, preceded by a 1-digit Header Tone, and followed by a 1-digit De-limiter Tone.

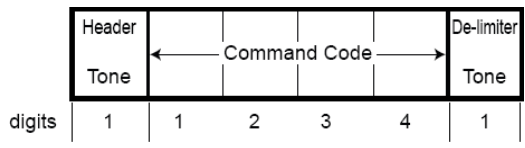

Header Tone

The Header tone is sent ahead of the command and indicates the start of the command. This tone is a fixed 1-digit from 0–9, A–D, *(E), #(F) (programmed using CS-FR3000). The default setting is *(E).

De-limiter Tone

The De-limiter is sent between commands and at the end of remote control codes. This tone indicates a space between segments of the command as well as the end of the command. This tone is a fixed 1-digit from 0–9, A–D, *(E), #(F) (programmed using CS-FR3000). The default setting is #(F).

Command Code

This field indicates the pre-programmed command or action to be executed. These codes are programmed to fixed 4-digit codes in cloning software, and may include characters from 0–9, A–D, *(E), #(F).

• Command code with sub code

The Command code with Sub code consists of basic command code and sub code (additionally required information).

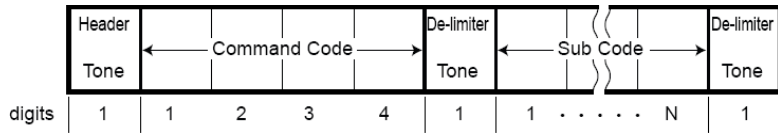

Sub Code

This field is entered following the command code and indicates a memory channel number (for Memory CH Select), an Autodial number (for Telephone Autodial), or a telephone number (for manual Tel dial commands). The Sub Code will be a fixed 2-digit code for Memory CH Select and Telephone Autodial commands or may be up to 24-digits for Tel dial command.

• Command with password and sub code continuously

This is the format required for entering commands for remote control operation.

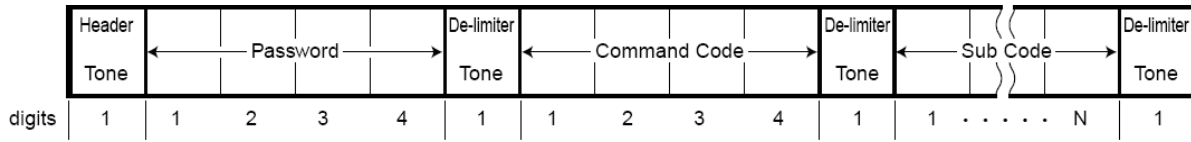

Password

The Password is a type of command code. The FR3000/FR4000 will enter the “System Control standby mode” when it receives this command while in normal operating mode. This is a fixed 4-digit code that is programmed using cloning software and may include digits from 0–9, A–D, *(E), #(F).



3-6-3 Command Table

1-3 COMMAND TABLE

Function	Default Code	During Normal mode		During Phone Patch mode		SUB code
		Transceiver	Phone	Transceiver	Phone	
System Control Exit	0002	✓	✓	✓ †	✓	—
Repeat Start	0003	✓	✓	—	—	—
Repeat Stop	0004	✓	✓	—	—	—
TX Start	0005	—	✓ ‡	— †	✓ ‡	—
TX Stop	0006	—	—	— †	✓	—
RF Power (Low)	0007	✓	✓	—	—	—
RF Power (High)	0008	✓	✓	—	—	—
RX Unit OFF	0009	—	✓	—	—	—
RX Unit ON	0010	—	✓	—	—	—
TX/RX Unit OFF	0011	—	✓	—	—	—
TX/RX Unit ON	0012	—	✓	—	—	—
Master Enable	0013	✓	✓	—	—	—
Slave Enable	0014	✓	✓	—	—	—
TEL Dial	0015	✓	—	✓	—	Max. 24 digits of telephone number
TEL Autodial	0016	✓	—	✓	—	2 digits Autodial channel number
Mch Select	0017	✓	✓	—	—	2 digits Memory channel number
CPU All Reset	0018	—	✓	—	—	—

† : When the Phone Patch mode is activated from the telephone, the repeater may recognize signals from a transceiver as being a signal from the telephone due to the sidetone function of the phone line. This will depend on the telephone company that provides local service.

‡ : “TX Start” is prohibited from the telephone line when “Slave Enable” (the backup repeater) is activated.



3-6-4 Command Descriptions

1-4 COMMAND DESCRIPTIONS

- **System Control Exit**
Turns OFF “System Control standby mode” and returns to normal operating mode. Will also “Hang up” the phone line during Phone Patch operation.
- **Repeat Start**
This command enables repeater operation. This command is not available during Phone Patch operation.
- **Repeat Stop**
This command inhibits repeater operation immediately even while transmitting. May be cancelled by entering “Repeat Start” command or power the repeater OFF/ON. This command is not available during Phone Patch operation.
- **TX Start**
This command initiates repeater transmit mode for Phone Patch operation. This command is available only when the signal is entered via the connected telephone line.
- **TX Stop**
This command stops the repeater from transmitting during Phone Patch operation. This command is available only when the signal is entered via the connected telephone line.
- **RF Power (Low)**
Switches TX power to “Low.” This command is not available during Phone Patch operation.
- **RF Power (High)**
Switches TX power to “High.” This command is not available for the channel which low power is programmed by cloning or during Phone Patch operation.
- **RX Unit OFF**
Turn OFF the RX unit (front end). This command is not available from a transceiver or during Phone Patch operation.
- **RX Unit ON**
Turn ON the RX unit (front end). This command is not available from a transceiver or during Phone Patch operation.
- **TX/RX Unit OFF**
Turn OFF the TX/RX units. This command is not available from a transceiver or during Phone Patch operation.
- **TX/RX Unit ON**
Turn ON the TX/RX units. This command is not available from a transceiver or during Phone Patch operation.
- **Master Enable**
Activates the master repeater when connected to a back up repeater. This command is not available during Phone Patch operation.
- **Slave Enable**
Activates the back up repeater when connected to a master repeater. This command is not available during Phone Patch operation.
- **TEL Dial**
Activates the phone line and dials the telephone number entered as sub code (max. 24 digits). Command will not activate when the first digit entered is the same as programmed in “Call Prohibition.” The repeater transmits “NG ACK” signal. This command is only available from a transceiver.
- **TEL Autodial**
Activates the phone line and dials the pre-programmed autodial channel (2 digits) as sub code. This command is only available from a transceiver.
- **Memory CH Select**
Selects the memory channel with sub code (2 digits Memory channel number). This command is not available during Phone Patch operation.
- **CPU All Reset**
Resets the repeater’s CPU. This command is not available from a transceiver or during Phone Patch operation.

1-5 OPERATION EXAMPLE

➤ System control command

NOTE:

- All commands must be entered within 10 sec. of entering a password. If the input time period runs out, you must enter the password again. This time period cannot be changed, so it is possible to enter the password and command continuously.
- When operating from the phone line the phone must be able to send DTMF signals.
- When the command is available from the transceiver and phone line, the operations are not different from both them other than the connecting and disconnecting way to the repeater.

The following examples assume these codes are pre-programmed in the repeater. Other commands are the same as default codes listed on command table (p. 36).

System Password: 0001,
Header Tone: *, De-limiter Tone: #
System Password OK ACK: 1111
System Control Exit ACK: 2020
OK ACK: 3333, NG ACK: 4040

➤ Repeat Start (0003 Default)

This command is available from **both the transceiver and phone line**. This explanation shows the step by step operation from the transceiver or operation from the phone line when entering the password and command continuously (one after the other).

[From the Transceiver]

- ① Enter the programmed password from the transceiver.
Code: *0001#
 - Verify the repeater replies "System Password OK ACK (1111)."
 - If the repeater replies "NG ACK (4040)," make sure the password, header tone and de-limiter tone are correct, and try again.
 - ② Enter the "Repeat Start" command within 10 sec.
Code: *0003#
 - Verify the repeater replies "OK ACK (3333)."
 - If the 10 sec. input standby time runs out, enter the password and command continuously (Code: *0001#0003#).
- The repeater starts the repeater operation.

[From the Phone line]

- ① Dial the phone number of the phone line that the repeater is connected to.
- ② When the connection has been confirmed, enter the following DTMF code.
Code: *0001#0003#
 - Verify the repeater replies "OK ACK (3333)."
 - If the repeater replies "NG ACK (4040)," make sure the password, header tone, de-limiter tone and Repeat Start code are correct, and try again.
 - The repeater starts the repeater operation.
- ③ Hang up the phone, the repeater automatically disconnects the phone.

➤ Repeat Stop (0004 Default)

This command is available from **both the transceiver and phone line**. This explanation shows the operation from the transceiver when entering the password and command continuously or step by step operation from the phone line (one after the other).

[From the Transceiver]

- Enter the following DTMF code from the transceiver.
Code: *0001#0004#
 - Verify the repeater replies "OK ACK (3333)."
 - If the repeater replies "NG ACK (4040)," make sure the password, header tone, de-limiter tone and Repeat Stop code are correct, and try again.
 - The repeater stops the repeater operation.

[From the Phone line]

- ① Dial the phone number of the phone line that the repeater is connected to.
- ② When the connection has been confirmed, enter the programmed password.
Code: *0001#
 - Verify the repeater replies "System Password OK ACK (1111)."
 - If the repeater replies "NG ACK (4040)," make sure the password, header tone and de-limiter tone are correct, and try again.
- ③ Enter the "Repeat Stop" command within 10 sec.
Code: *0004#
 - Verify the repeater replies "OK ACK (3333)."
 - If the 10 sec. input standby time runs out, enter the password and command continuously (Code: *0001#0004#).
 - The repeater stops the repeater operation.
- ④ Hang up the phone, the repeater automatically disconnects the phone.



Operation Example

➤ RF Power (Low) (0007 Default)

This command is available from **both the transceiver and phone line**. This explanation shows the step by step operation from the transceiver or operation from the phone line when entering password and command continuously (one after the other).

This command cannot be performed while repeater is transmitting, therefore you must stop the repeater operation before changing RF power.

[From the transceiver]

- ① Enter the programmed password from the transceiver.
Code: *0001#
 - Verify the repeater replies “System Password OK ACK (1111).”
 - If the repeater replies “NG ACK (4040),” make sure the password, header tone and de-limiter tone are correct, and try again.
- ② Enter the “Repeat Stop” command within 10 sec.
Code: *0004#
 - Verify the repeater replies “OK ACK (3333).”
 - If the 10 sec. input standby time runs out, enter the password and command continuously (Code: *0001#0004#).
- ③ Enter the “RF Power (Low)” command within 10 sec.
Code: *0007#
 - Verify the repeater replies “OK ACK (3333).”
 - If the 10 sec. input standby time runs out, enter the password and command continuously (Code: *0001#0007#).
 - The repeater changes transmit power High to Low.
- ④ Enter the “Repeat Start” command within 10 sec.
Code: *0003#
 - Verify the repeater replies “OK ACK (3333).”
 - If the 10 sec. input standby time runs out, enter the password and command continuously (Code: *0001#0003#).

[From the Phone line]

- ① Dial the phone number of the phone line that the repeater is connected to.
- ② When the connection has been confirmed, enter the following DTMF code.
Code: *0001#0004#
 - Verify the repeater replies “OK ACK (3333).”
 - If the repeater replies “NG ACK (4040),” make sure the password, header tone, de-limiter tone and Repeat Stop code are correct, and try again.
- ③ Enter the “RF Power (Low)” command within 10 sec.
Code: *0007#
 - Verify the repeater replies “OK ACK (3333).”
 - If the 10 sec. input standby time runs out, enter the password and command again (Code: *0001#0007#).
 - The repeater changes transmit power High to Low.
- ④ Enter the “Repeat Start” command within 10 sec.
Code: *0003#
 - Verify the repeater replies “OK ACK (3333).”
 - If the 10 sec. input standby time runs out, enter the password and command again (Code: *0001#0003#).
- ⑤ Hang up the phone, the repeater automatically disconnects the phone.



Operation Example

➤ RF Power (High) (0008 Default)

This command is available from **both the transceiver and phone line**. This explanation shows the operation from the transceiver when entering the password and command continuously or step by step operation from the phone line (one after the other).

This command cannot be performed while repeater is transmitting, therefore you must stop the repeater operation before changing RF power.

[From the transceiver]

- ① Enter the following DTMF code from the transceiver.
Code: *0001#0004#
 - Verify the repeater replies “OK ACK (3333).”
 - If the repeater replies “NG ACK (4040),” make sure the password, header tone, de-limiter tone and Repeat Stop code are correct, and try again.
- ② Enter the “RF Power (High)” command within 10 sec.
Code: *0008#
 - Verify the repeater replies “OK ACK (3333).”
 - If the 10 sec. input standby time runs out, enter the password and command continuously (Code: *0001#0008#).
 - The repeater changes transmit power Low to High.
- ③ Enter the “Repeat Start” command within 10 sec.
Code: *0003#
 - Verify the repeater replies “OK ACK (3333).”
 - If the 10 sec. input standby time runs out, enter the password and command continuously (Code: *0001#0003#).

[From the Phone line]

- ① Dial the phone number of the phone line that the repeater is connected to.
- ② When the connection has been confirmed, enter the programmed password.
Code: *0001#
 - Verify the repeater replies “System Password OK ACK (1111).”
 - If the repeater replies “NG ACK (4040),” make sure the password, header tone and de-limiter tone are correct, and try again.
- ③ Enter the “Repeat Stop” command within 10 sec.
Code: *0004#
 - Verify the repeater replies “OK ACK (3333).”
 - If the 10 sec. input standby time runs out, enter the password and command continuously (Code: *0001#0004#).
- ④ Enter the “RF Power (High)” command within 10 sec.
Code: *0008#
 - Verify the repeater replies “OK ACK (3333).”
 - If the 10 sec. input standby time runs out, enter the password and command continuously (Code: *0001#0008#).
 - The repeater changes transmit power Low to High.
- ⑤ Enter the “Repeat Start” command within 10 sec.
Code: *0003#
 - Verify the repeater replies “OK ACK (3333).”
 - If the 10 sec. input standby time runs out, enter the password and command continuously (Code: *0001#0003#).
- ⑥ Hang up the phone, the repeater automatically disconnects the phone.



Operation Example

➤ RX Unit OFF (0009 Default)

This command is available from **the phone line only**. This explanation shows the step by step operation. You can carry out the command operation either step by step, or by entering the password and command continuously.

- ① Dial the phone number of the phone line that the repeater is connected to.
- ② When the connection has been confirmed, enter the programmed password.
Code: *0001#
 - Verify the repeater replies “System Password OK ACK (1111).”
 - If the repeater replies “NG ACK (4040),” make sure the password, header tone and de-limiter tone are correct, and try again.
- ③ Enter the “RX Unit OFF” command within 10 sec.
Code: *0009#
 - Verify the repeater replies “OK ACK (3333).”
 - If the 10 sec. input standby time runs out, enter the password and command continuously (Code: *0001#0009#).
 - The repeater turns the RX unit (front end) OFF.
- ④ Hang up the phone, the repeater automatically disconnects the phone.

➤ RX Unit ON (0010 Default)

This command is available from **the phone line only**. This explanation shows entering the password and command continuously. You can carry out the command operation either step by step, or by entering the password and command continuously.

- ① Dial the phone number of the phone line that the repeater is connected to.
- ② When the connection has been confirmed, enter the following DTMF code.
Code: *0001#0010#
 - Verify the repeater replies “OK ACK (3333).”
 - If the repeater replies “NG ACK (4040),” make sure the password, header tone, de-limiter tone and RX Unit ON code are correct, and try again.
 - The repeater turns the RX unit (front end) ON.
- ③ Hang up the phone, the repeater automatically disconnects the phone.

➤ TX/RX Unit OFF (0011 Default)

This command is available from **the phone line only**. This explanation shows entering the password and command continuously. You can carry out the command operation either step by step, or by entering the password and command continuously.

- ① Dial the phone number of the phone line that the repeater is connected to.
- ② When the connection has been confirmed, enter the following DTMF code.
Code: *0001#0011#
 - Verify the repeater replies “OK ACK (3333).”
 - If the repeater replies “NG ACK (4040),” make sure the password, header tone, de-limiter tone and TX/RX Unit OFF code are correct, and try again.
 - The repeater turns the TX/RX units OFF.
- ③ Hang up the phone, the repeater automatically disconnects the phone.

➤ TX/RX Unit ON (0012 Default)

This command is available from **the phone line only**. This explanation shows the step by step operation. You can carry out the command operation either step by step, or by entering the password and command continuously.

- ① Dial the phone number of the phone line that the repeater is connected to.
- ② When the connection has been confirmed, enter the programmed password.
Code: *0001#
 - Verify the repeater replies “System Password OK ACK (1111).”
 - If the repeater replies “NG ACK (4040),” make sure the password, header tone and de-limiter tone are correct, and try again.
- ③ Enter the “TX/RX Unit ON” command within 10 sec.
Code: *0012#
 - Verify the repeater replies “OK ACK (3333).”
 - If the 10 sec. input standby time runs out, enter the password and command continuously (Code: *0001#0012#).
 - The repeater turns the TX/RX units ON.
- ④ Hang up the phone, the repeater automatically disconnects the phone.



Operation Example

➤ Master Enable (0013 Default)

This command is available from **both the transceiver and phone line**. This explanation shows the step by step operation from the transceiver or operation from the phone line when entering the password and command continuously (one after the other).

[From the Transceiver]

- ① Enter the programmed password from the transceiver.
Code: *0001#
 - Verify the repeater replies “System Password OK ACK (1111).”
 - If the repeater replies “NG ACK (4040),” make sure the password, header tone and de-limiter tone are correct, and try again.
- ② Enter the “Master Enable” command within 10 sec.
Code: *0013#
 - Verify the repeater replies “OK ACK (3333).”
 - If the 10 sec. input standby time runs out, enter the password and command continuously (Code: *0001#0013#).
 - The operating repeater switches to the Master repeater.

[From the Phone line]

- ① Dial the phone number of the phone line that the repeater is connected to.
- ② When the connection has been confirmed, enter the following DTMF code.
Code: *0001#0013#
 - Verify the repeater replies “OK ACK (3333).”
 - If the repeater replies “NG ACK (4040),” make sure the password, header tone, de-limiter tone and Master Enable code are correct, and try again.
 - The operating repeater switches to the Master repeater.
- ③ Hang up the phone, the repeater automatically disconnects the phone.

➤ Slave Enable (0014 Default)

This command is available from **the transceiver and phone line**. This explanation shows the operation from the transceiver when entering the password and command continuously or step by step operation from the phone line (one after the other).

[From the Transceiver]

- Enter the following DTMF code from transceiver.
Code: *0001#0014#
 - Verify the repeater replies “OK ACK (3333).”
 - If the repeater replies “NG ACK (4040),” make sure the password, header tone, de-limiter tone and Slave Enable code are correct, and try again.
 - The operating repeater switches to the Slave repeater.

[From the Phone line]

- ① Dial the phone number of the phone line that the repeater is connected to.
- ② When the connection has been confirmed, enter the programmed password.
Code: *0001#
 - Verify the repeater replies “System Password OK ACK (1111).”
 - If the repeater replies “NG ACK (4040),” make sure the password, header tone and de-limiter tone are correct, and try again.
- ③ Enter the “Slave Enable” command within 10 sec.
Code: *0014#
 - Verify the repeater replies “OK ACK (3333).”
 - If the 10 sec. input standby time runs out, enter the password and command continuously (Code: *0001#0014#).
 - The operating repeater switches to the Slave repeater.
- ④ Hang up the phone, the repeater automatically disconnects the phone.



Operation Example

➤ **Mch Select** (0017 Default)

This command is available from **both the transceiver and phone line**. This explanation shows the step by step operation from the transceiver or operation from the phone line when entering the password and command continuously (one after the other).

This command cannot be performed while repeater is transmitting, therefore you must stop the repeater operation before selecting a different memory channel.

[From the transceiver]

- ① Enter the programmed password from the transceiver.
Code: *0001#
 - Verify the repeater replies “System Password OK ACK (1111).”
 - If the repeater replies “NG ACK (4040),” make sure the password, header tone and de-limiter tone are correct, and try again.
- ② Enter the “Repeat Stop” command within 10 sec.
Code: *0004#
 - Verify the repeater replies “OK ACK (3333).”
 - If the 10 sec. input standby time runs out, enter the password and command continuously (Code: *0001#0004#).
- ③ Enter the “Mch Select” command followed by sub code within 10 sec.
Code: *0017#07#
(when your intended channel is 07)
 - Verify the repeater replies “OK ACK (3333).”
 - If the 10 sec. input standby time runs out, enter the password and command continuously (Code: *0001#0017#07#).
 - The repeater changes to the memory channel 7.
- ④ Enter the “Repeat Start” command within 10 sec.
Code: *0003#
 - Verify the repeater replies “OK ACK (3333).”
 - If the 10 sec. input standby time runs out, enter the password and command continuously (Code: *0001#0003#).

[From the Phone line]

- ① Dial the phone number of the phone line that the repeater is connected to.
- ② When the connection has been confirmed, enter the following DTMF code.
Code: *0001#0004#
 - Verify the repeater replies “OK ACK (3333).”
 - If the repeater replies “NG ACK (4040),” make sure the password, header tone, de-limiter tone and Repeat Stop code are correct, and try again.
- ③ Enter the “Mch Select” command followed by sub code within 10 sec.
Code: *0017#07#
(when your intended channel is 07)
 - Verify the repeater replies “OK ACK (3333).”
 - If the 10 sec. input standby time runs out, enter the password and command continuously (Code: *0001#0017#07#).
 - The repeater changes to the memory channel 7.
- ④ Enter the “Repeat Start” command within 10 sec.
Code: *0003#
 - Verify the repeater replies “OK ACK (3333).”
 - If the 10 sec. input standby time runs out, enter the password and command continuously (Code: *0001#0003#).
- ⑤ Hang up the phone, the repeater automatically disconnects the phone.



Operation Example

➤ CPU All Reset (0018 Default)

This command is available from **the phone line only**. This explanation shows entering the password and command continuously.

This command cannot be performed while repeater is transmitting, therefore you must stop the repeater operation before performing CPU All Reset.

- ① Dial the phone number of the phone line that the repeater is connected to.
- ② When the connection has been confirmed, enter the following DTMF code.
Code: *0001#0004#
 - Verify the repeater replies “OK ACK (3333).”
 - If the repeater replies “NG ACK (4040),” make sure the password, header tone, de-limiter tone and Repeat Stop code are correct, and try again.
- ③ Enter the “CPU All Reset” command within 10 sec.
Code: *0018#
 - Verify the repeater replies “OK ACK (3333).”
 - If the 10 sec. input standby time runs out, enter the password and command continuously (Code: *0001#0018#).
 - The repeater performs CPU All Reset.
- ④ Enter the “Repeat Start” command within 10 sec.
Code: *0003#
 - Verify the repeater replies “OK ACK (3333).”
 - If the 10 sec. input standby time runs out, enter the password and command continuously (Code: *0001#0003#).
- ⑤ Hang up the phone, the repeater automatically disconnects the phone.

Basic Repeater to Phone Line Connecting System

The IC-FR3000/FR4000 repeater can be connected directly to the telephone line. When a subscriber transmits a DTMF dialing codes, the repeater, received signal is sent to the telephone line to connect the phone.

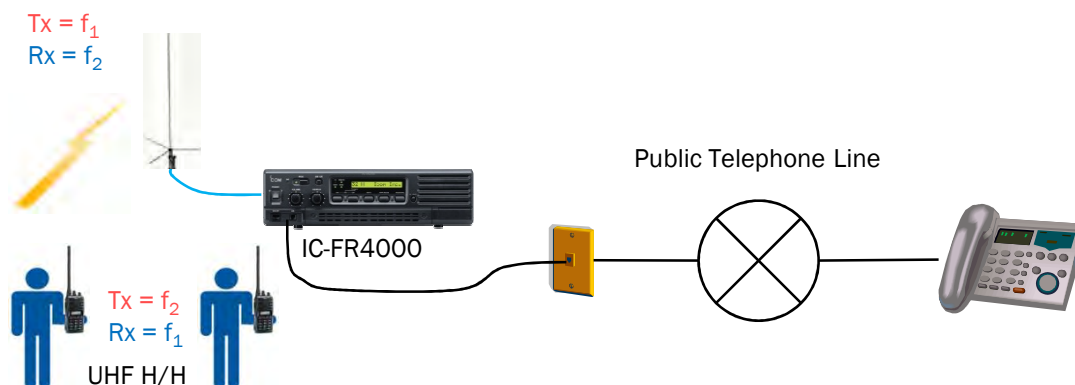

System requirement

Descriptions	Model Number	Quantity
UHF Repeater	IC-FR4000	
UHF Antenna		
Duplexer		
Telephone Line		

➤ DTMF Setting

To enable connect phone line functions, the DTMF settings must be pre-programmed using CS-FR3000 cloning software. Use CS-FR3000 help screens for description of functions and operation and for programming details.

NOTE: Cannot call to phone line from transceiver when the repeater is working in PMR mode and the operating channel of 5-Tone format is set to DTMF.

➤ Operation from the transceiver

One of two methods (Dial and Auto-dial) of telephone access is selectable from the transceiver. Auto-dial: Using the pre-programmed phone No. (up to 20 channels are stored) in the repeater. Dial: Direct dialing from the keypad of a transceiver.

TEL Autodial (0016 Default)

Autodial number: 12 (Channel 12)

- ① Enter the following DTMF codes.
 - Code: *0001#0016#12#
 - Verify the repeater replies “OK ACK (3333).”
 - If the repeater replies “NG ACK (4040),” make sure the password, header tone, de-limiter tone and command code are correct, and try again.
 - The repeater starts calling the autodial channel 12.
- ② When the connection has been confirmed, talk to the phone by simplex voice communication.
- ③ After conversation is finished enter the password followed by the “System Control Exit” command to terminate Phone Patch operation.
 - Code: *0001#0002#
 - Verify the repeater replies “System Control Exit ACK (2020),” then repeater hangs on the phone.

TEL Dial (0015 Default)

- ① Enter the programmed password from transceiver.
 - Code: *0001#
 - Verify the repeater replies “System Password OK ACK (1111).”
 - If the repeater replies “NG ACK (4040),” make sure the password, header tone and de-limiter tone are correct, and try again.
- ② Enter the “TEL Dial” command within 10 sec.
 - Code: *0015#
 - Verify the standby time runs out, enter the password and command continuously (Code: *0001#0015#).
- ③ Enter the telephone number (if the number is 060-3355-2244) as sub code within 10 sec.
 - Code: *06033552244#
 - Verify the repeater replies “OK ACK (3333).”
 - If the 10 sec. input standby time runs out, enter the password and command continuously (Code: *0001#0015#06033552244#).
 - The repeater starts calling the number.
- ④ When the connection has been confirmed, talk to the phone by simplex voice communication.
- ⑤ After conversation is finished enter the password followed by the “System Control Exit” command to terminate Phone Patch operation.
 - Code: *0001#0002#
 - Verify the repeater replies “System Control Exit ACK (2020),” then repeater hangs on the phone.

Phone Line to Repeater Connection for Phone Patch and Remote Control Function

The IC-FR3000/FR4000 repeater can be connected to the telephone line. Phone Patch function allows communication to a transceiver from a telephone line, or connection to a telephone line from a transceiver. During the Phone Patch operation, the voice communication is simplex. (The mute control is activated from the transceiver's continuous tone SQL.)

System requirement

Descriptions	Model Number	Quantity
UHF Repeater	IC-FR4000	
UHF Antenna		
Duplexer		
Telephone Line		
Phone Patch Interface		

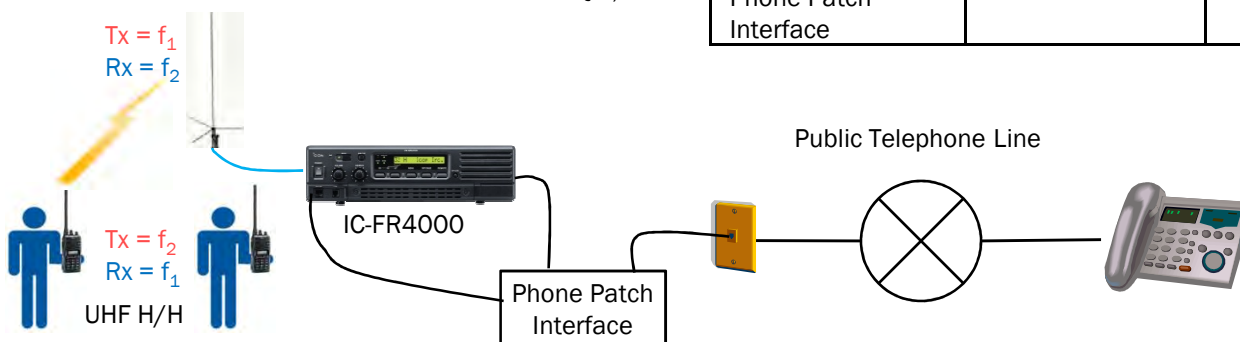

Connection Example between Phone Patch Interface and Repeater

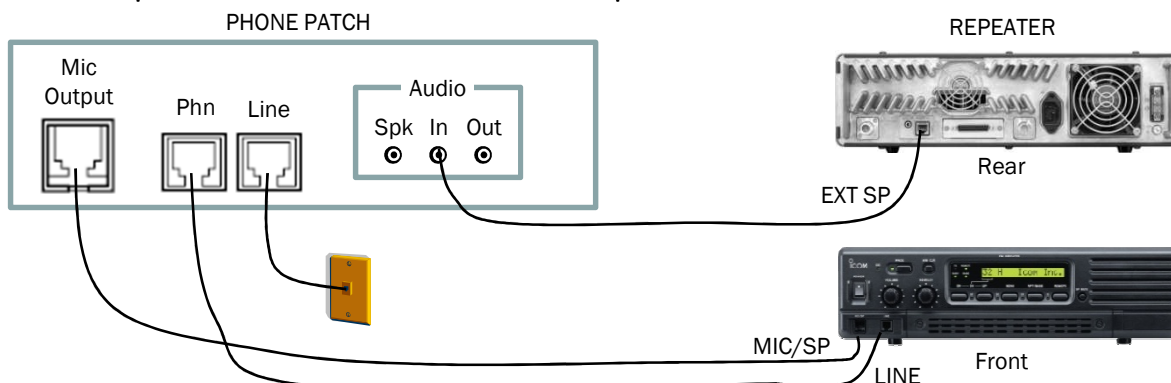

■ Operation from the phone line

➤ TX Start (0005 Default)

Step by step operation from the phone line.

- ① Dial the phone number of the phone line that the repeater is connected to.
- ② When the connection has been confirmed, enter the programmed password.
Code: *0001#
 - Verify the repeater replies "System Password OK ACK (1111)."
 - If the repeater replies "NG ACK (4040)," make sure the password, header tone and de-limiter tone are correct, and try again.
- ③ Enter the "TX Start" command within 10 sec.
Code: *0005#
 - Verify the repeater replies "OK ACK (3333)."
 - If the 10 sec. input standby time runs out, enter the password and command continuously (Code: *0001#0005#).

- The repeater starts the downlink transmission for Phone Patch operation.

- ④ After conversation is finished, hang up the phone, the repeater automatically disconnects the phone and stops the downlink transmission.

➤ TX Stop (0006 Default)

During Phone Patch operation this command stops repeater from transmitting, for changing repeater settings.

- ① Enter the following DTMF code (password and command code).
Code: *0001#0006#
 - Verify the repeater replies "OK ACK (3333)."
 - If the repeater replies "NG ACK (4040)," make sure the password, header tone, de-limiter tone and TX stop code are correct, and try again.
- ② You may continue remote control operation from the phone line to make other settings in the repeater, or hang up the phone if there is nothing else to change.

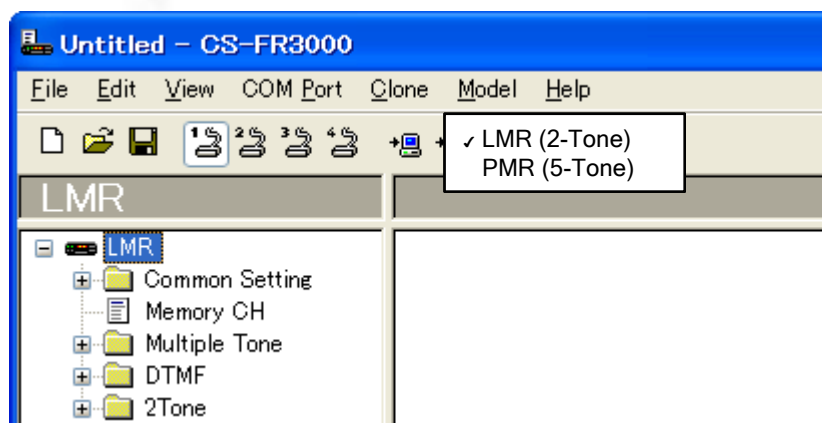

What is 2-Tone Signalling?

1. Originally called "Quick Call", this signalling protocol was developed by Motorola in the 1950's.
2. 2-Tone (Quick Call) was designed to add Squelch specificity especially for emergency service radios.
3. LMR consists of two distinct signals sent over the air to a radio or a group.
4. Each tone can be configured within a 250 Hz and 3300 Hz tone frequency.
5. Normally, the duration of the tones varies from one (1) to three (3) seconds in length no space between the tones. Tone lengths of up to 10 seconds are commonly seen in existing applications.
6. ICOM radios allow variable tone periods and spaces (no tone) between the tones.

2-Tone Features

1. "Selective Calling" – allows the dispatch console to page an individual unit. It allows 1 (one) encoding tone set per channel or up to 3 (three) receive tones in the radio.
2. "Group Calling" - allows the dispatch console to page a group.
3. "Answer Back Call" – Also known as "Radio Check" allows the dispatch console or another portable, to send a tone to a particular radio and when the target radio receives the tone it answers back with another tone. This function serves as a tool to verify if a unit is "ON" and within range.
4. "Auto Transmit" – Also known as "Radio Spy" allows the dispatcher to send a 2-Tone signal to the radio causing it to open its transmitter microphone audio (Hot Mic) in order to listen to whatever is happening in the proximity of the radio. This is also very useful in emergency cases where the user may not be able to trigger the microphone.

5. "Stun/Kill" – This function allows the dispatch console to disable, temporarily or permanently, a unit using the 2-Tone capabilities. When "Stun" is used, the unit may regain its functionality by entering a password. When Kill is used, the radio only regains functionality by reprogramming the unit using the cloning software.
6. RX Code Text – Allows the programmer to add an "Alpha Numeric" text tag to each tone for identification at decode and encode if the unit has a display.
7. Variable Signals – This allows the user/programmer to set the "Beep and Bell" to different formats for easier identification when a signal is received.

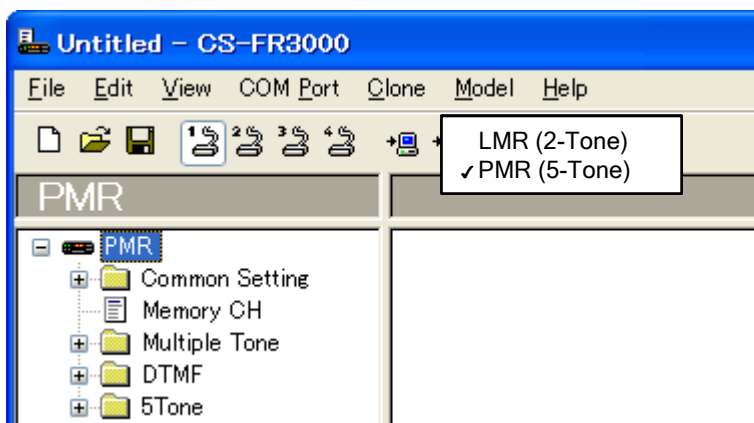

What is 5-Tone Signalling?

1. Although it is dubbed as 5-Tone, this signalling protocol consists of a fast data burst of one (1) to seven (7) frequency tones that can selectively signal a radio.
2. Originally a European signalling protocol, 5-Tone has numerous formats such as:
 - a. CCIR
 - b. ZVEI1
 - c. ZVEI2
 - d. DZV1
 - e. EEA
 - f. EEA2
 - g. DAPL
 - h. EIA
 - i. DTMF (Dual Tone Multi Frequency)
3. EIA is the International Open Standard set by the Electronics Industries Association.
4. 5-Tone adds specificity to the squelch abilities of commercial radios.

Where to activate 5-Tone

1. Enable the repeater in PMR mode by selecting the PMR Model in the Model section of the cloning software.
2. To create the 5-Tone TX list, click on the 5-Tone folder and select the "TX Code CH" icon.
3. In this section the user can create up to 32 encode able tone sequences.
4. Each of these tone sequences can be identified with an alias on the list.

5-Tone Format Structure

1. Unlike 2-Tone, where the programmer must know the frequency to be used on each tone, 5-Tone does not require knowledge of the frequencies to be used.
2. Each digit in the sequence is already predefined with a specific frequency depending on the format selected in the Tone form section of the programming.
3. All the programmer needs to know is what format is being used and what code needs to do what. The system does the rest.

If there was a need, although it is not highly recommended, the tone formats can be modified to specific needs.

4. The 5-Tone Format section of programming allows the programmer to view and modify three (3) aspects of the 5-Tone format.
 - Tone Period - is the length of the encoded tone.
 - Notone Timer - is the space required between tones for proper decoding (tone spread).
 - Tone Length - is the time the radio takes to decode a tone.

NOTE: ICOM strongly recommends that programmers do NOT alter any data in the Format screen



5-Tone (PMR) Signalling

Why chose 5-Tone?

1. 5-Tone is a non-proprietary signalling protocol that allows the Icom radio to inter-operate with other brands using the 5-Tone signalling.
2. This protocol also allows a mixed fleet operation.
3. It is faster than 2-Tone by employing a quick data burst.
4. Customers are familiar with the protocol since it is an Industry Standard in USA, Europe, and Asia.
5. Many manufacturers built dispatch consoles with this capability.
6. 5-Tone offers flexible muting characteristics.

5-Tone Features

1. Selective Calling” – allows the dispatch console to page an individual unit.
2. “Group Calling” - allows the dispatch console to page a group.
3. “Answer Back Call” – Also known as “Radio Check” allows the dispatch console to send a 5-Tone sequence to a particular radio and when the target radio receives the tone it answers back with another tone. This function serves as a tool to verify if a unit is “ON” and within range.
4. “Auto Transmit” – Also known as “Radio Spy” allows the dispatcher to send a 5-Tone signal to the radio causing it to open its transmitter microphone audio (Hot Mic) in order to listen to whatever is happening in the proximity of the radio. This is also very useful in emergency cases where the user may not be able to trigger the microphone.
5. “Stun/Kill – This function allows the dispatch console to disable temporarily or permanently a unit using the 5-Tone capabilities. When “Stun” is used, the unit may regain its functionality by entering a password. When Kill is used, the radio only regains functionality by reprogramming the unit using the cloning software.
6. 5-Tone allows the PTT ID functionality on the repeater.
7. As with 2-Tone, PMR also provides audible alerts, emergency signalling and Dispatch functionality making it a workable upgrade to an existing fleet.

5-Tone Enhancements

1. The PMR model and repeater functionality provides the programmer with RX Text identifiers. When a particular 5-Tone sequence is received, a repeater with display will show the alias attributed to that tone sequence.
2. This repeater also has variable audible signals and beeps.
3. When transmitting a 5-Tone sequence, the repeater can select from a programmed list with aliases in order to identify the code desired for TX.
4. PMR repeaters allow for TX code editing and the creation of a custom “User Code” that will allow the programmer to create a unique code for a customer.
5. The system also allows for a user to select the TX codes by assigning a button on the repeater.

What is DTMF?

DTMF (dual tone multi frequency) is the sounds used for touch tone dialing.

Each number and character (0 to 9, A, B, C, D, E (*), and F (#)) is represented by a pair of tones.

The following table shows the DTFM frequencies and the corresponding number and characters.

▪ Frequency/Number, Character Matrix Table

		High Frequency (Hz)			
		1209	1336	1477	1633
Low Frequency (Hz)	697	1	2	3	A
	770	4	5	6	B
	852	7	8	9	C
	941	* (E)	0	# (F)	D

▪ Two Pure Sine Waves combine for form the DTMF Tone

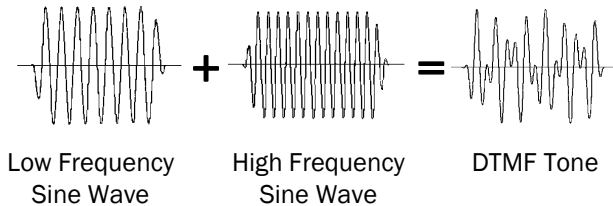

DTMF Features

- Autodial (20 numbers) is available for Emergency (LMR), Log/ID (LMR), Alert and TEL Autodial are used for Emergency call.
- It is possible to setup LCD Blinking indicators, variable audible signals and beeps to activate when receiving matched RX code.
- This repeater automatically responds a System Password OK ACK, System Control Exit ACK, OK ACK, and NG ACK when receiving a matched DTMF code.
- “Stun/Kill – This function allows the dispatch console to disable temporarily or permanently a unit using the DTMF capabilities. When “Stun” is used, the unit may regain its functionality by entering a password. When Kill is used, the radio only regains functionality by reprogramming the unit using the cloning software.
- The repeater functionality provides the programmer with RX Text identifiers. When a matched DTMF code is received, a repeater will display the pre-programmed text.
- The System Control function allows control of the repeater from a remote location over the air or over a phone line with DTMF.

➤ System Control

The System Control function is ON when a matched DTMF code is received.

NOTE: A different code from the header tone must be set. The de-limiter tone is also combined with the system control command.

The de-limiter tone is used to end a command, as well as for a sub command for a system command to be received.

▶ Example ◀

Header tone: A
 De-limiter tone: #
 System command: 1234
 Sub command: 01
 Total remote control code; A1234#01#

➤ RX System Code

For programming DTMF codes of 4 digits in the following items.

The item activates when receiving a matched DTMF code.

Input code 0000 (or OFF)

To turn OFF the item:

However, "System Password" cannot be set to OFF. ("0000" is recognized as a code.)

- 0001 System Password - Moves to system control mode.
- 0002 System Control Exit - Exits the system control mode.
- 0003 Repeat Start - Starts the Repeater operation.
- 0004 Repeat Stop - Stops the Repeater operation.
- 0005 TX Start - Starts to transmit.
- 0006 TX Stop - Stops to transmit.
- 0007 RF Power (Low) - Transmits by low power.
- 0008 RF Power (High) - Transmits by low power.
- 0009 RX Unit OFF - Turns the RX unit OFF.
- 0010 RX Unit ON - Turns the RX unit ON.
- 0011 RX/TX Unit OFF - Turns the RX and TX unit OFF.
- 0012 RX/TX Unit ON - Turns the RX and TX unit ON.
- 0013 Master Enable - Enables the Master of the back-up function.
- 0014 Slave Enable - Enables the Slave (sub) of the back-up function.
- 0015 TEL Dial - Calls by the transceiver.
- 0016 TEL Autodial - Calls by the speed dialing.
- 0017 Mch Select - Changes the memory channel.
- 0018 CPU All Reset - Resets the CPU.

➤ TX System Code

Program DTMF codes for response of 4 digits in the following items.

- 1111 System Password OK ACK
- 2020 System control Exit ACK
- 3333 OK ACK
- 4040 NG ACK

Voice scrambling function

The optional voice scrambler unit provides high performance private communication between stations with the same scrambler code. The 32 code non-rolling-type voice scrambler UT-109 and 1020 code rolling type UT-110 are available.

➤ Variable Split and Frequency Inversion

This is the scrambling system employed in the UT-109 and UT-110. The audio frequency band is divided at a specified frequency (divided frequency) and high and low audio frequencies in each band are inverted. The divided frequency is programmable with cloning.

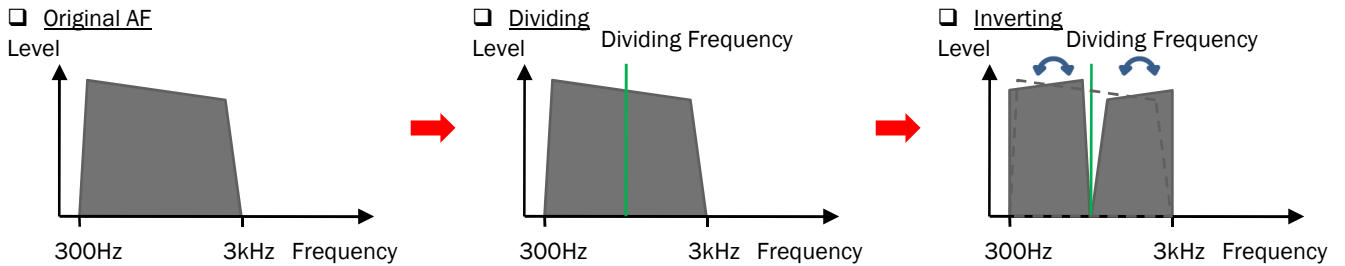

➤ Difference between rolling and non-rolling types

The rolling type (in fact, hopping type is used for the UT-110) is an additional feature which provides higher communication security. It changes the divided frequency over a specified period.

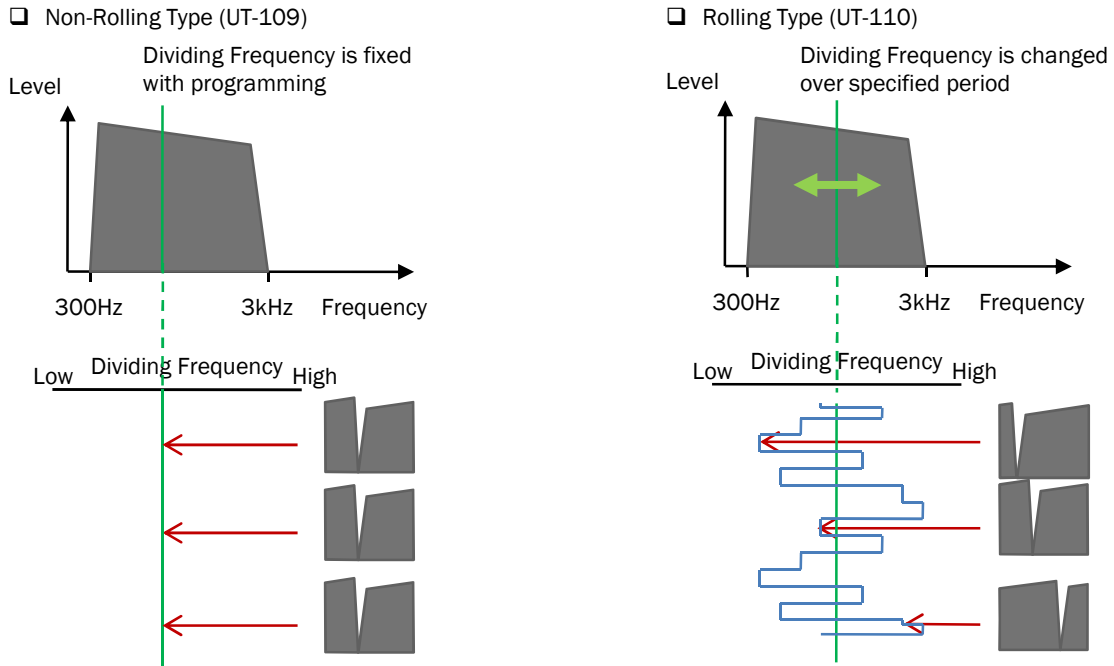

Program setting for scrambler



Non-rolling-type voice
scrambler UT-109



Rolling type voice
scrambler UT-110

➤ Memory CH - Scrambler

• Scrambler OFF/ON/Inhibit

OFF : Turn the scrambler function OFF.

ON : Turn the scrambler function ON.

Inhibit : Scrambler function selection is inhibited.

NOTE:

This setting is only effective for the base mode.

RELATED ITEM:

[Scrambler] ; Common screen

• Scrambler Code

- Program the scrambler codes.

- Available codes;

UT-109 (Non-rolling type) : 1 to 32

UT-110 (Rolling type) : 1 to 255

NOTE:

- Set the scrambler group code in the Common 2 screen in advance. (UT-110 only)

- UT-110 can be program the group number 1 to 4. Then totality 1020 (4 group * 255) code numbers are available.

- Set the scrambler type in the Common 2 screen. By selecting Non-rolling type in this item, you can use UT-110 as UT-109.

- This setting is only effective for the base mode.

RELATED ITEMS:

• Synchronous capture :Common 2 screen (UT-110 only)

• Tone Start Timing :Common 2 screen (UT-110 only)

➤ Common - Scrambler

• Type

Set the UT-110 Rolling type scrambler as UT-109 Non-rolling type. As UT-110 and UT-109 have different code settings, they are not compatible.

By selecting Non-rolling type in this item, you can use UT-110 as UT-109.

Selectable value: Rolling type (UT-110 normal) or Non-rolling type (UT-110 works as UT-109)

NOTE:

1. This item is invalid for UT-109.

2. The following setting will be invalid; Scrambler Group Code

• Group Code

Set the Scrambler Group code number. available number: 1 to 4

NOTE: This item is invalid for UT-109.

• Synchronous Capture

"Synchronous capture mode" is useful when communicating through a repeater. However, because of voice components, the repeater can not maintain synchronous mode in rare cases. Normally it is best to set this item to "Standard".

Selectable value: Standard (normal operation) or Continuous (repeater operation)

• Tone Start Timing

Tone start timing selects the synchronous tone signal transmit delay time. Set the delay time for the other party's transceiver has power save mode.

Selectable value: OFF(default), 300, 600 and 1100 msec.



4 Applications

4-1 Repeater Linking System - 1



Basic Repeater Linking System

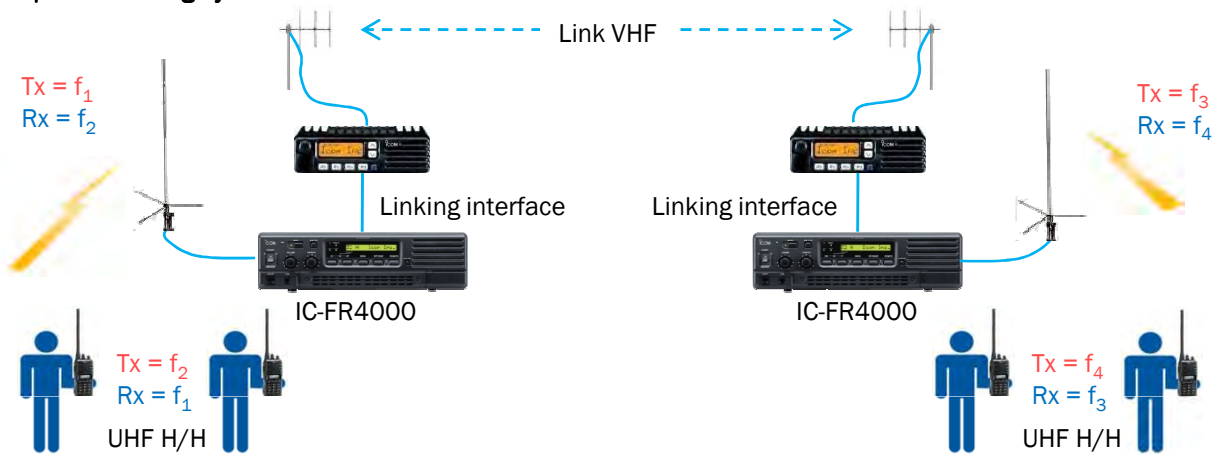

A repeater extends communications service area and it is very useful for two-way communications. Everyone thinks that the service area should be as wide as possible such as a cellular phone system. Now the service area can be extended with Icom repeaters!

This is a basic plan to upgrade the repeater site to a link system. This plan is suitable for linking two or more repeater sites. When a subscriber transmits, the repeater re-transmits a received signal. At the same time, the received signal is sent to another repeater site, through a VHF mobile radio. These VHF radios work as link radios between repeater sites.

System requirements (One site)

Descriptions	Model Number	Quantity
UHF Repeater	IC-FR4000	
UHF Antenna		
Duplexer		
VHF Mobile Radio	IC-F111	
VHF Antenna		
Power Supply		
Duplexer		
ACC Cable	OPC-617	
Interface Cable	25p to 9p	

Connection example



Connect two repeaters by interface cable (25p to 9p).

These interface cables are not sold as Icom accessories, therefore please assemble the interface cable by yourself. The connection diagram is as follows;

Repeater (25pin)		OPC-617 (9pin)
Pin 1 (BUSY OUT)	↔	Pin 5 (PTT CONT IN.)
Pin 10 (EXTMOD IN A)	↔	Pin 3 (DET. AF OUT)
Pin 11 (AF OUT)	↔	Pin 4 (MOD IN)
Pin 19 (EXT PTT)	↔	Pin 1 (HORN DRIVE)
Pin 21-24 (GND)	↔	Pin 8 (DET AF GND) Pin 9 (MOD GND)

Repeater Linking System - 2



Basic Repeater Linking System

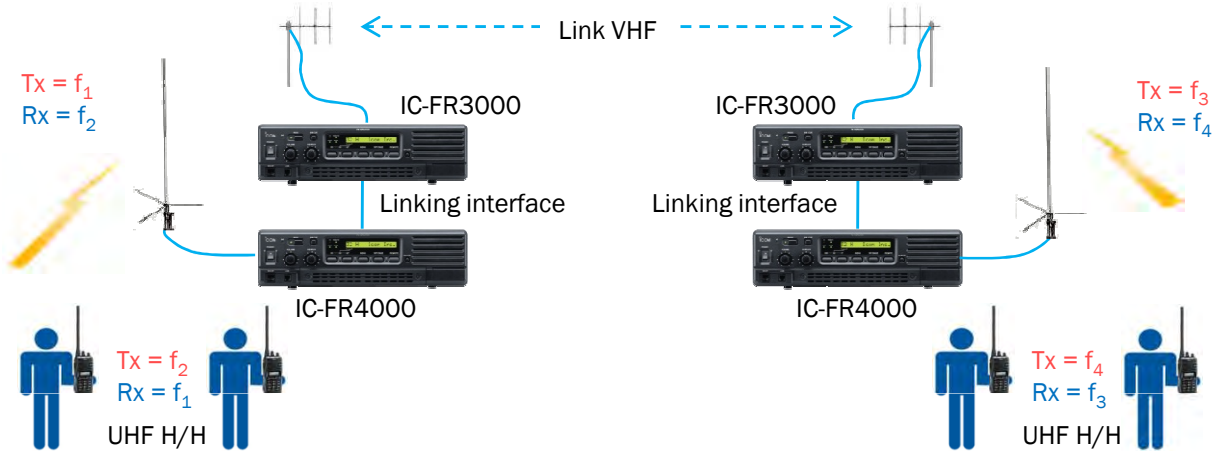

This is an advanced plan to upgrade the repeater site to a link system. An ICOM repeater also works as a base station (simplex), therefore this system is more versatile. Applicable for repeater link, cross-band repeater, etc..

System requirement (One site)

Descriptions	Model Number	Quantity
UHF Repeater	IC-FR4000	
UHF Antenna		
Duplexer		
VHF Repeater	IC-FR3000	
VHF Antenna		
Duplexer		
Interface Cable	25p to 25p	

Connection example

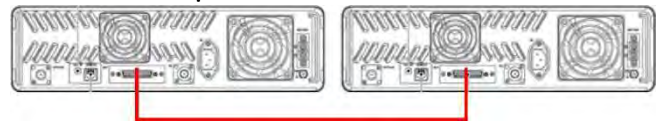

Connect two repeaters by interface cable (25p to 25p).

These interface cables are not sold as Icom accessories, therefore please assemble the interface cable by yourself. The connection diagram is as follows;

Repeater (25pin)		Repeater (25pin)
Pin 1 (BUSY OUT)	↔	Pin 19 (EXT PTT)
Pin 10 (EXTMOD IN A)	↔	Pin 11 (AF OUT)
Pin 11 (AF OUT)	↔	Pin 10 (EXTMOD IN A)
Pin 19 (EXT PTT)	↔	Pin 1 (BUSY OUT)
Pin 21-24 (GND)	↔	Pin 21-24 (GND)

Repeater Linking System - 3

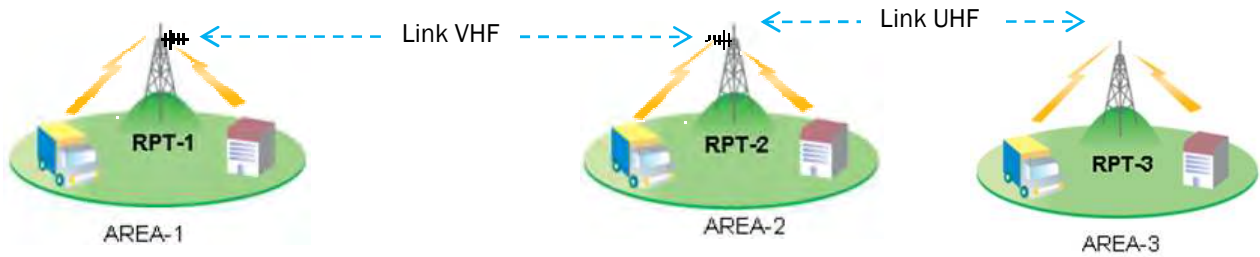

Advanced Repeater Linking System

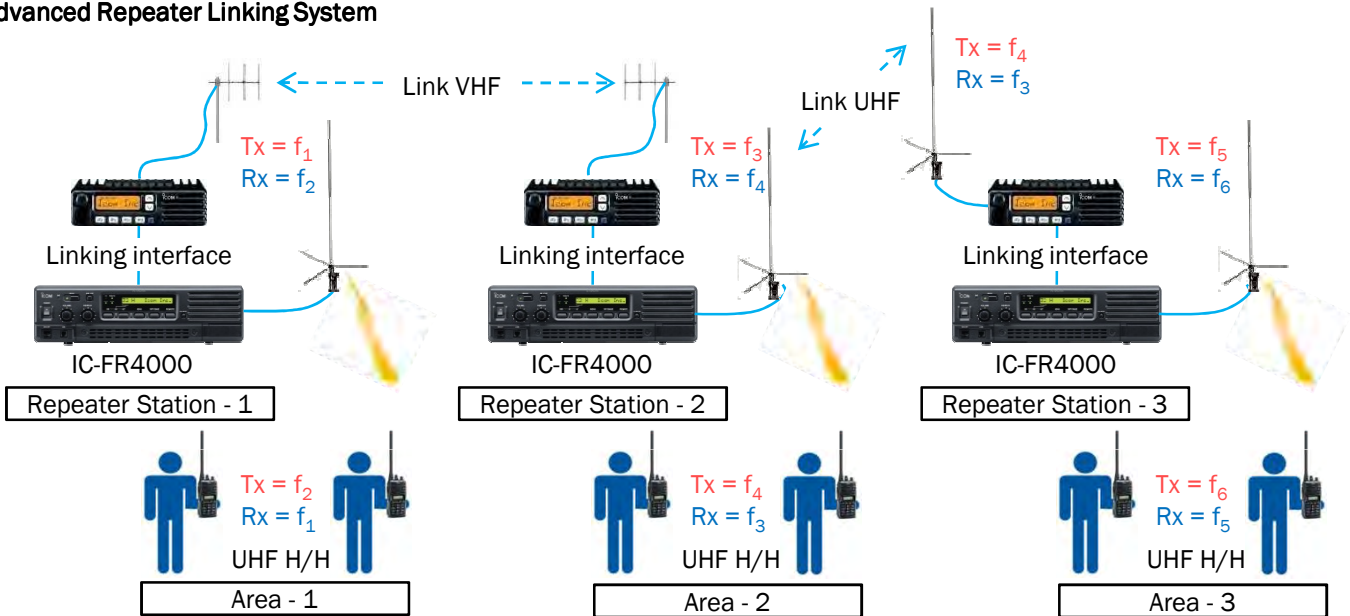

This is an advanced plan to upgrade the repeater site to a link system. This plan is suitable for linking three repeater sites. When a subscriber transmits, the repeater re-transmits a received signal. At the same time, the received signal is sent to another repeater site, through VHF mobile radios and UHF mobile radios. These VHF and UHF radios work as link radios between repeater sites.

Descriptions	Model Number	Quantity
UHF Repeater	IC-FR4000	
UHF Antenna		
Duplexer		
VHF Mobile Radio	IC-F111	
VHF Antenna		
UHF Mobile Radio	IC-F211	
UHF Antenna		
Power Supply		
Duplexer		
ACC Cable	OPC-617	
Interface Cable	25p to 9p	

Connection example



Connect two repeaters by interface cable (25p to 9p).

These interface cables are not sold as Icom accessories, therefore please assemble the interface cable by yourself. The connection diagram is as follows;

Repeater (25pin)		OPC-617 (9pin)
Pin 1 (BUSY OUT)	↔	Pin 5 (PTT CONT IN.)
Pin 10 (EXTMOD IN A)	↔	Pin 3 (DET. AF OUT)
Pin 11 (AF OUT)	↔	Pin 4 (MOD IN)
Pin 19 (EXT PTT)	↔	Pin 1 (HORN DRIVE)
Pin 21-24 (GND)	↔	Pin 8 (DET AF GND) Pin 9 (MOD GND)

IC-F110 / IC-F121, IC-F210 / IC-F221

Opening the case

- ① Unscrew 4 screws A, and remove the bottom cover.
- ② Disconnect the flat cable B from J2.
- ③ Disconnect the cable C from J7.
- ④ Unscrew 2 screws D, and remove the front unit.

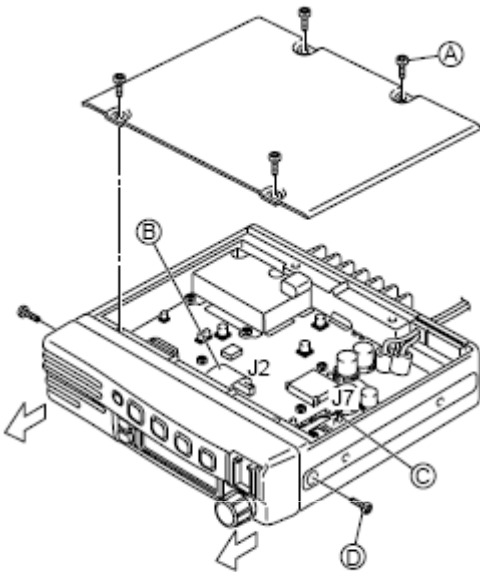

Make soldering bridge at the point "F".

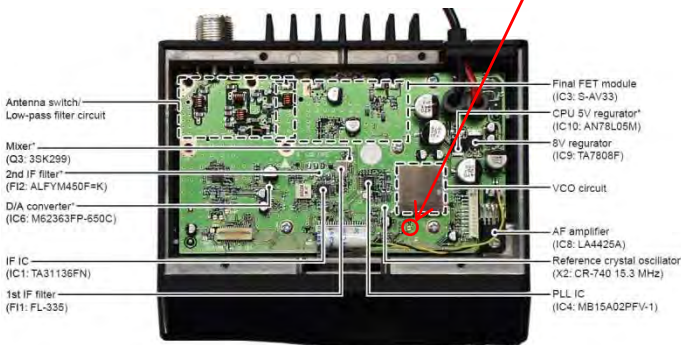

* Located under side of the point.

IC-FR3000/IC-FR3100, IC-FR4000/IC-FR4100

1. Software setting (CS-FR3000)

If repeater is operated as "Closed repeater" which requires CTCSS to access the repeater, it is recommended to program the setting of the ACC connector as follows. This is effective to prevent unwanted relaying by interference or noise.



2. Repeater setting

Press [REMOTE] key on the front panel to activate the remote function. If this is turned OFF, relaying operation does not work. This setting cannot be programmed by cloning, therefore this must be set manually.

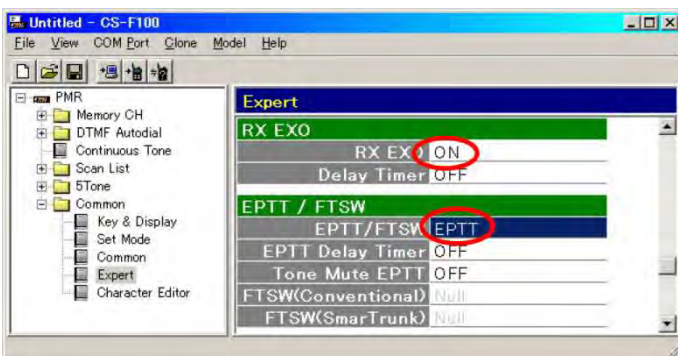



4-2 MPT1327 Trunking System

* All diagrams in this section show a 3 channel system example.

Single Site Trunking System

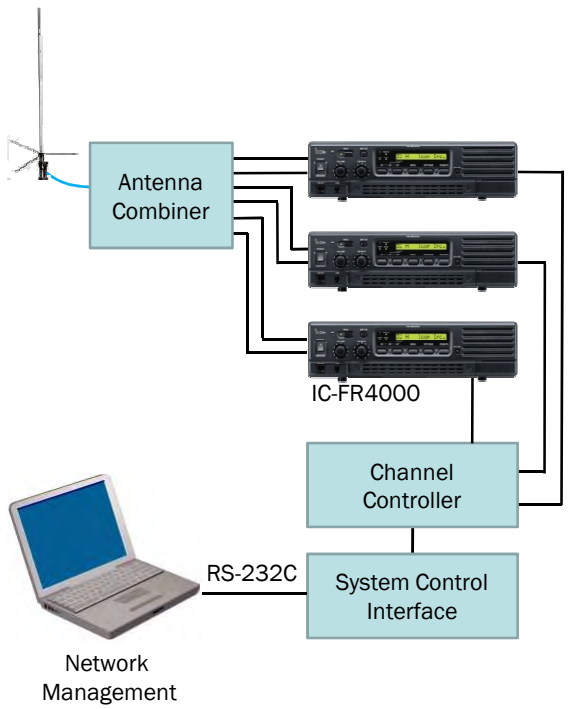

Single Site Trunking System with telephone line connection

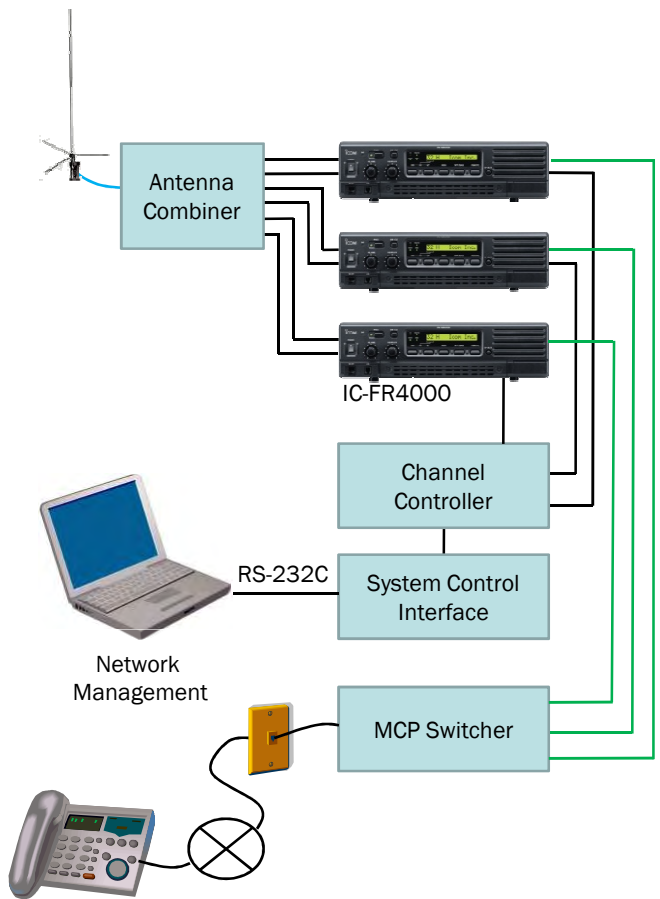

The IC-FR3000/IC-FR4000 series has D-SUB 25 pin/modular interfaces for external controllers such as PassPort® and MPT1327. MPT1327 is a signalling standard for trunked private land mobile radio systems. It defines the protocol rules for communication between a trunking system controller (TSC) and users' radio units. This is a basic plan to upgrade the repeater site to a trunking system. This plan is an example of a single trunking repeater site.

This is an example to upgrade to a telephone connection added to a single trunking repeater site.

System requirements (One site)

Descriptions	Model Number	Quantity
UHF Repeater	IC-FR4000	
UHF Antenna		
Antenna Combiner		
Channel Controller		
System Control IF		
PC		
Management Software		

System requirements with Telephone connection (One site)

Descriptions	Model Number	Quantity
UHF Repeater	IC-FR4000	
UHF Antenna		
Antenna Combiner		
Channel Controller		
System Control IF		
PC		
Management Software		
MCP Switcher		
PSTN or PABX		

Single Site Trunking System with telephone line connection

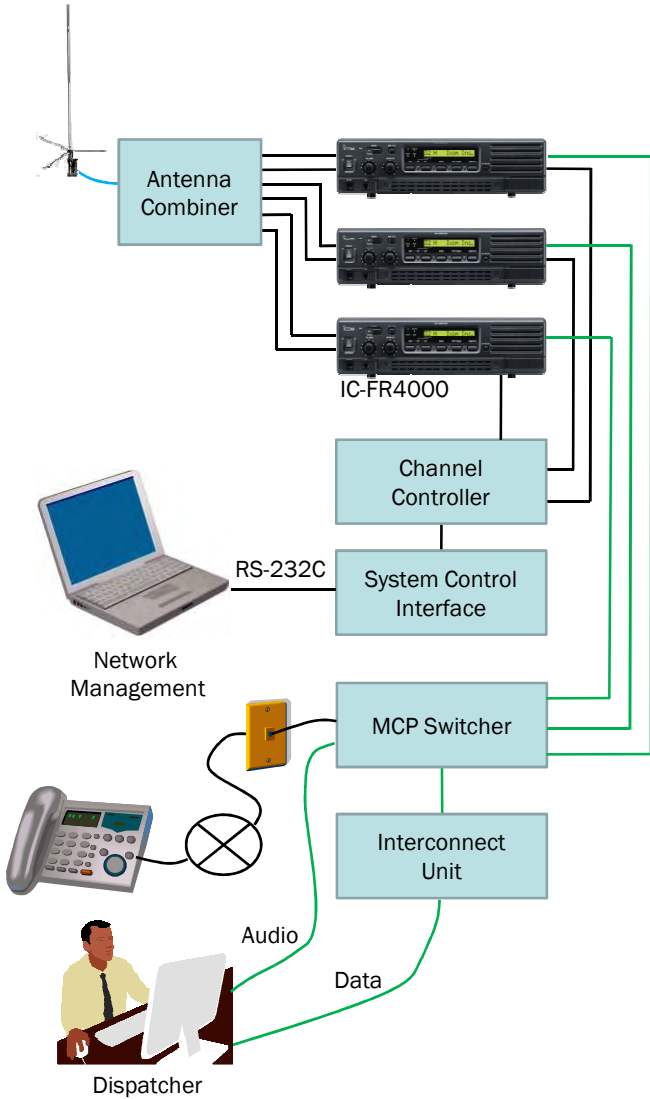

This is an example to upgrade to a telephone and data connection added to the single trunking repeater site.

System requirements (One site)

Descriptions	Model Number	Quantity
UHF Repeater	IC-FR4000	
UHF Antenna		
Antenna Combiner		
Channel Controller		
System Control IF		
PC		
Management Software		
MCP Switcher		
Interconnect Unit		
PSTN or PABX		

Single Site Trunking System with telephone line connection and Vehicle and Personnel Tracking

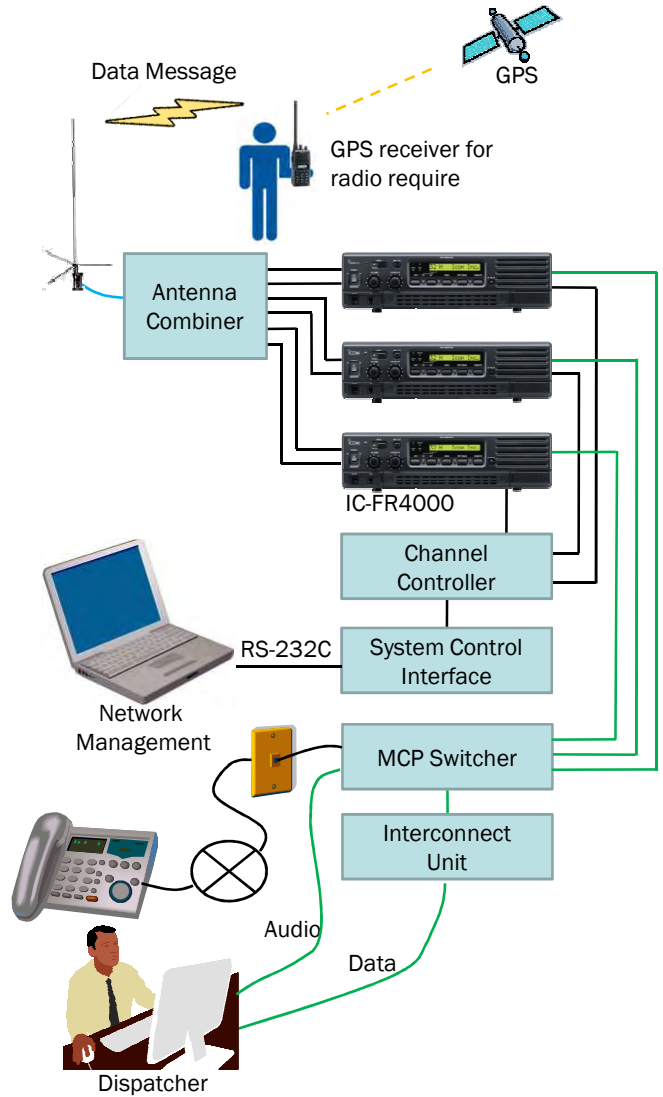

This is an example to upgrade to a telephone and data connection added to the single trunking repeater site. It also enables expansion to Vehicle and Personnel Tracking.

System requirements (One site)

Descriptions	Model Number	Quantity
UHF Repeater	IC-FR4000	
UHF Antenna		
Antenna Combiner		
Channel Controller		
System Control IF		
PC		
Management Software		
MCP Switcher		
Interconnect Unit		
Mapping Software		
PSTN or PABX		

Regional Trunking System

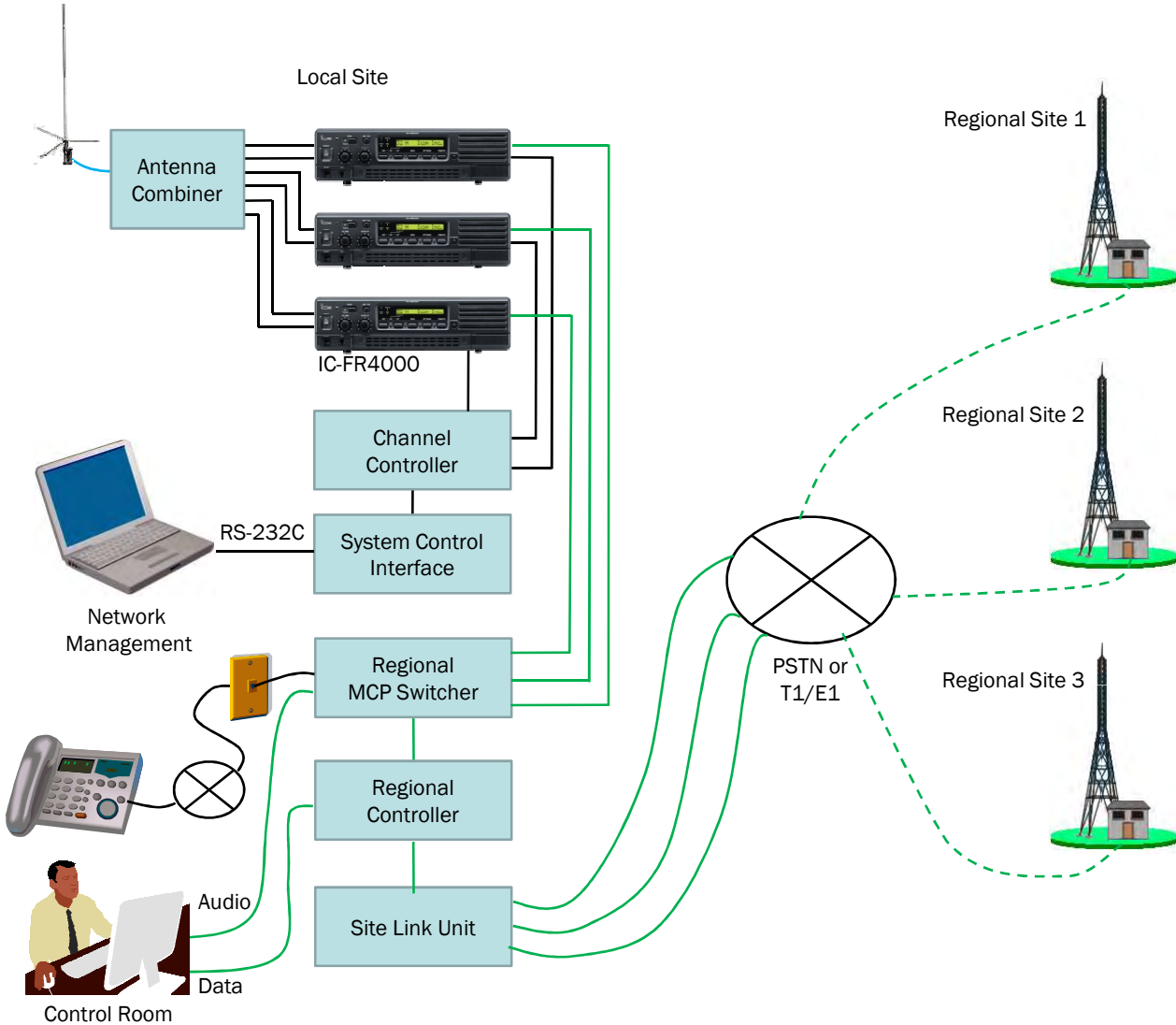

This is a plan to upgrade to a site linked regional trunking system.

System requirement (One site)

Descriptions	Model Number	Quantity
UHF Repeater	IC-FR4000	
UHF Antenna		
Antenna Combiner		
Channel Controller		
System Control IF		
PC		
Management Software		
Regional MCP Switcher		
Regional Controller		
PSTN/PABX or T1/E1		



4-3 LTR® Trunking System

4-3-1 Single Site LTR® Trunking System

* All diagrams in this section show a 3 channel system example.

Single Site LTR® Trunking System

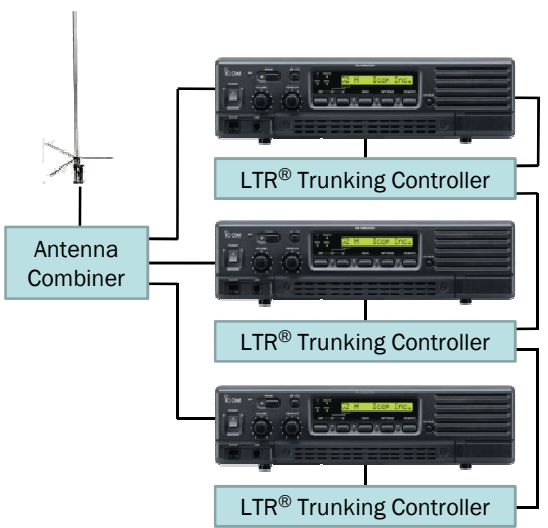

Single Site LTR® Trunking System with Telephone Line Connection

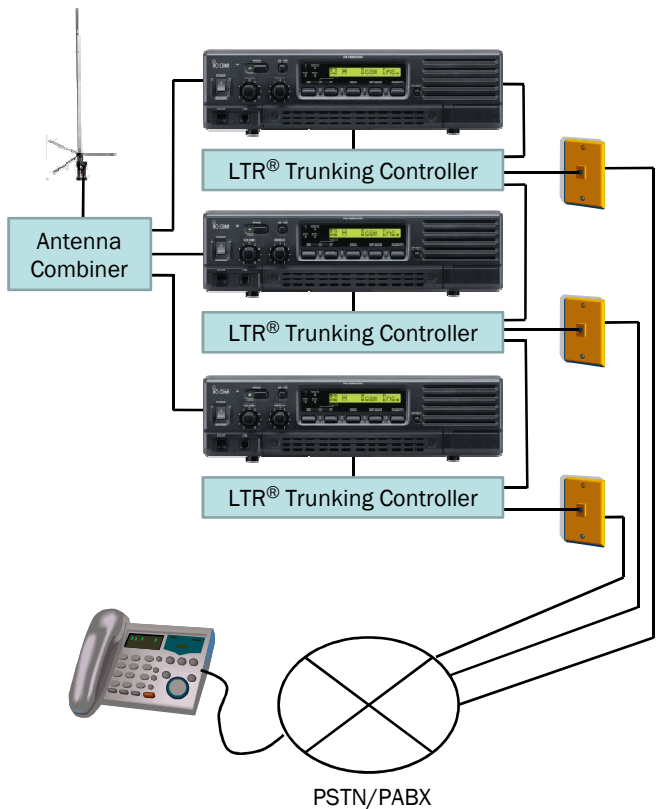

The IC-FR3000/IC-FR4000 series has D-SUB 25 pin/modular interfaces for external controllers such as LTR®, PassPort® and MPT1327. LTR® is a signalling standard for trunked private land mobile radio systems. It defines the protocol rules for communication between a trunking system controller and users' radio units. This plan is an example of single trunking repeater site .

This is an example to upgrade to a telephone connection added to the single trunking repeater site.

System requirements (One site)

Descriptions	Model Number	Quantity
UHF Repeater	IC-FR4000	
UHF Antenna		
Antenna Combiner		
Trunking Controller		

System requirements (One site)

Descriptions	Model Number	Quantity
UHF Repeater	IC-FR4000	
UHF Antenna		
Antenna Combiner		
Trunking Controller		
PSTN or PABX		



4-3-2 Digital Networked LTR® or PassPort® Trunking System

Digital Networked LTR® or PassPort® Trunking System

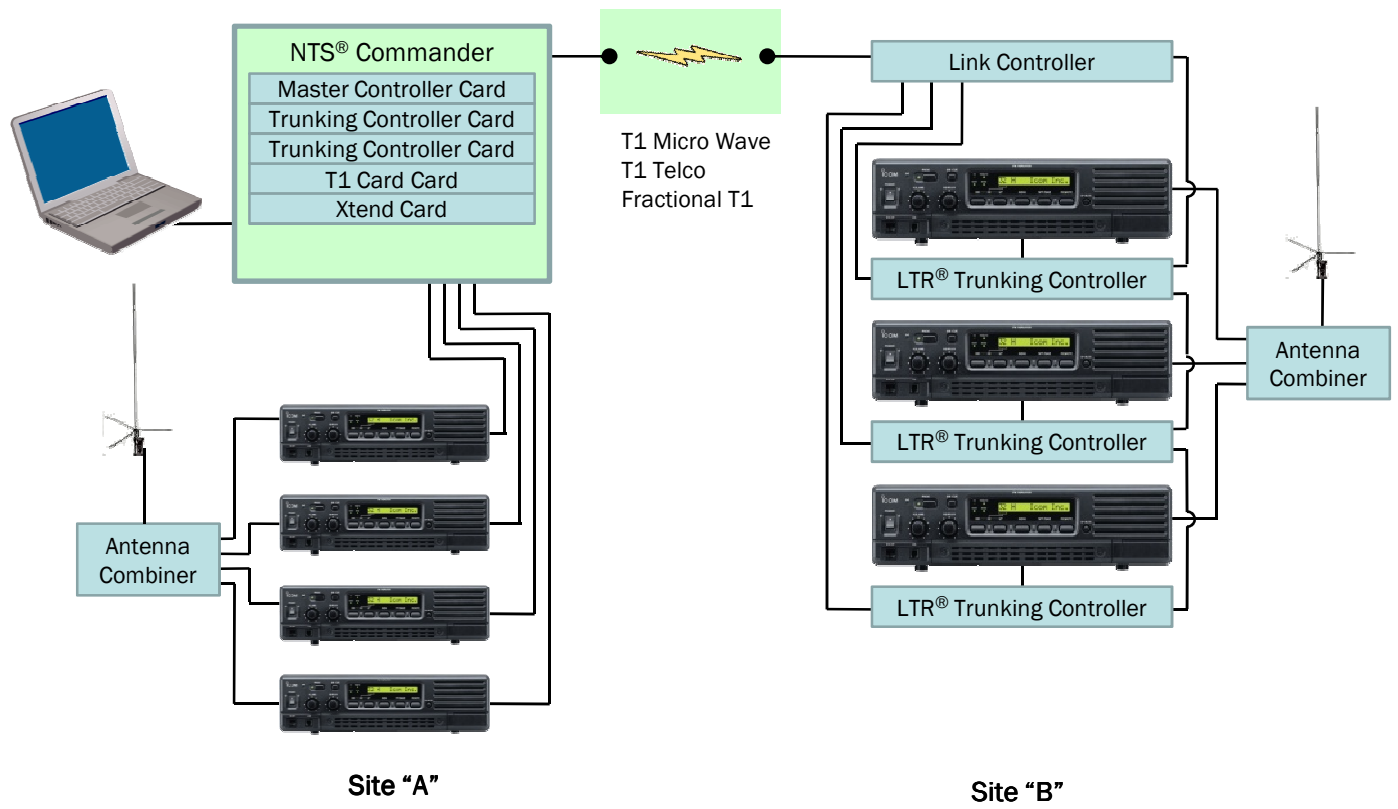

This is an example to upgrade to a digital network added to the single trunking repeater site.

System requirements (Site "A")

Descriptions	Model Number	Quantity
UHF Repeater	IC-FR4000	
UHF Antenna		
Antenna Combiner		
NTS® Commander		
Master Controller Card		
Trunking Controller Card		
T1 Card Card		
Xtend Card		
PC		

System requirements (Site "B")

Descriptions	Model Number	Quantity
UHF Repeater	IC-FR4000	
UHF Antenna		
Antenna Combiner		
Trunking Controller		
Link Controller		



4-3-3 Analog Networked LTR[®] or PassPort[®] Trunking System

Analog Networked LTR[®] or PassPort[®] Trunking System

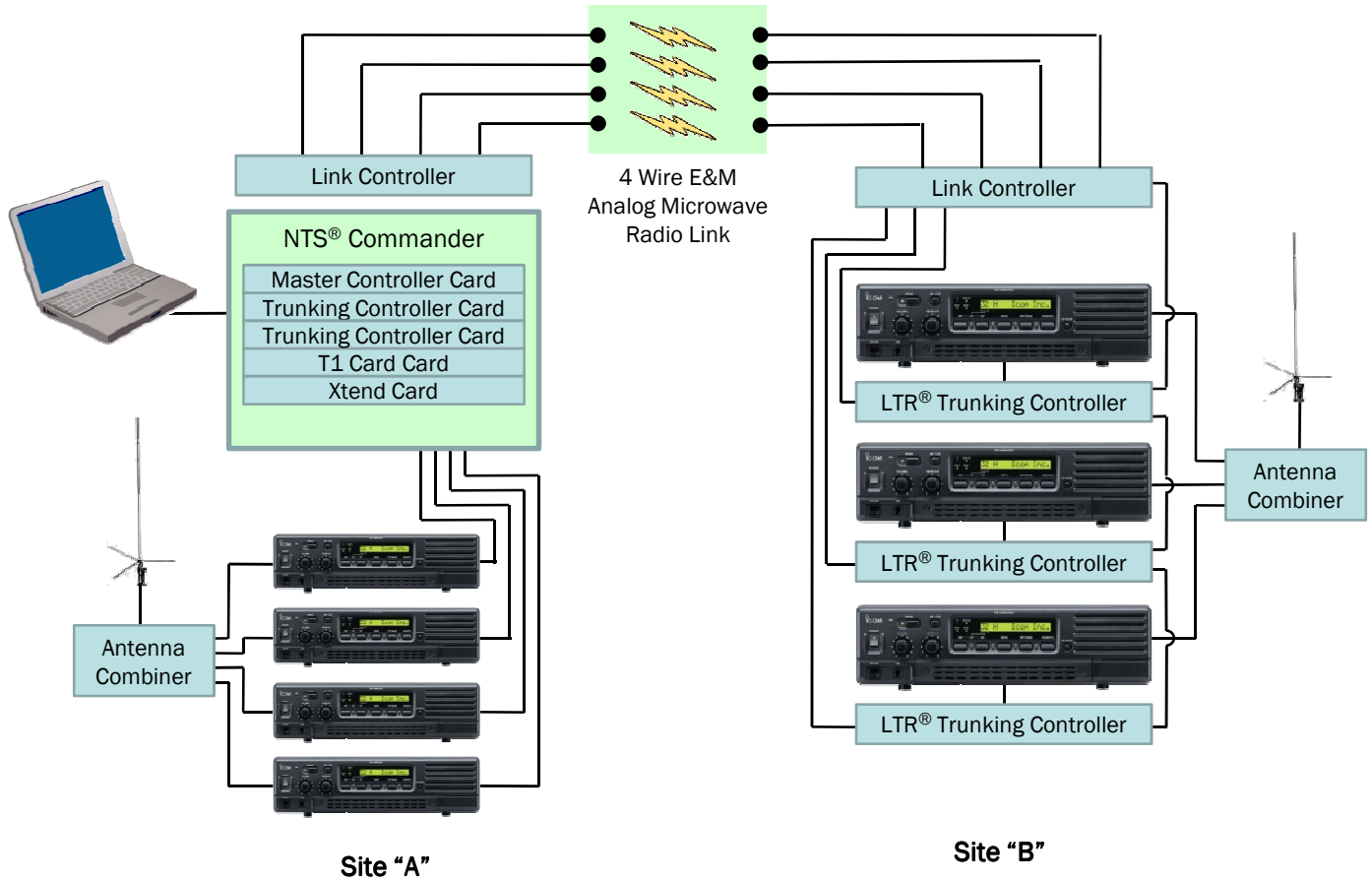

This is an example to upgrade for analog network added to the single trunking repeater site.

System requirements (Site "A")

Descriptions	Model Number	Quantity
UHF Repeater	IC-FR4000	
UHF Antenna		
Antenna Combiner		
Link Controller		
NTS [®] Commander		
Master Controller Card		
Trunking Controller Card		
T1 Card Card		
Xtend Card		
PC		

System requirements (Site "B")

Descriptions	Model Number	Quantity
UHF Repeater	IC-FR4000	
UHF Antenna		
Antenna Combiner		
Trunking Controller		
Link Controller		



4-4 Solar Powered Repeater System

DC load only solar power system

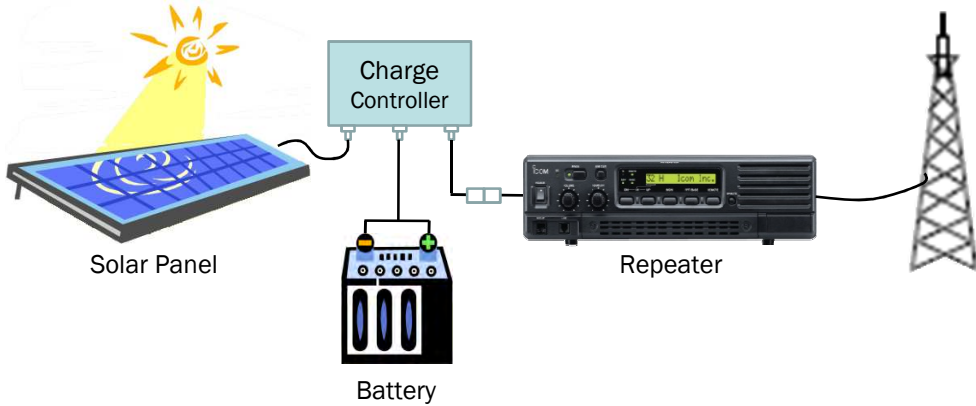

Descriptions	Model Number	Quantity
Solar Panel		
Charge Controller		
Battery		
Repeater		
Antenna		

DC and AC load combined solar power system

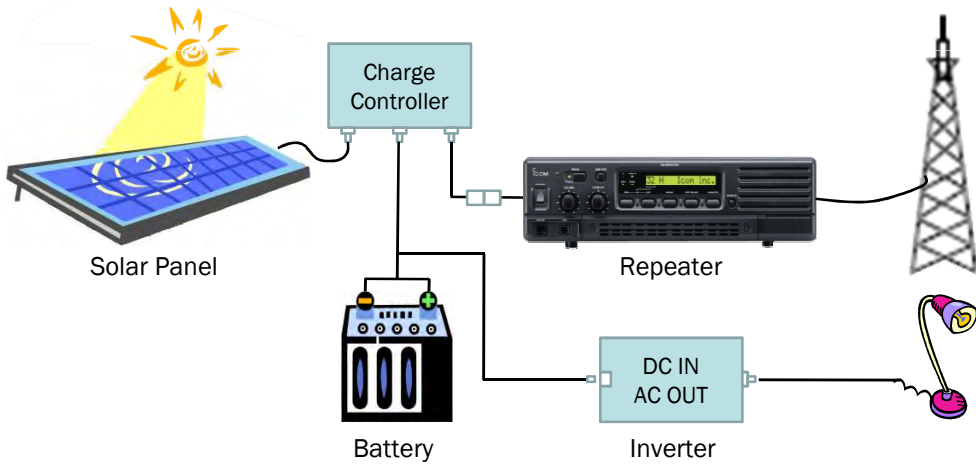

Descriptions	Model Number	Quantity
Solar Panel		
Charge Controller		
Battery		
Inverter		
Repeater		
Antenna		



Solar Powered Repeater System

➤ Solar power system

In order to design a solar power system you will have to first determine your estimated electrical needs.

Determine How Much Electricity You Will Use

- Calculate Your Total Daily Amp Hour usage
- Calculate how many Solar Panels you will need
- Calculate what size of Batteries you will need

➤ Calculate Your Total Daily Amp Hour usage

AC Loads						
List AC load items	Quantity	X	Watts	X	Hrs/week	= Wh/week
_____	_____		_____		_____	_____
_____	_____		_____		_____	_____
_____	_____		_____		_____	_____
Total Wh/week						_____ - ①
DC watt hours per week. Multiply line ① by 1.15 to correct for inverter loss.						_____ - ②
Inverter DC input voltage; This is DC system voltage.						12 - ③
Divide line ② by line ③. This is total amp hours per week used by AC loads.						_____ - ④

DC Loads						
List DC load items	Quantity	X	Watts	X	Hrs/week	= Wh/week
_____	_____		_____		_____	_____
_____	_____		_____		_____	_____
_____	_____		_____		_____	_____
Total Wh/week						_____ - ⑤
DC system voltage.						12 - ⑥
Total amp hours per week used by DC loads. Divide line ⑤ by line ⑥.						_____ - ⑦
Total amp hours per week used by AC loads from line ④						_____ - ⑧
Add lines ⑦ and ⑧. This is total amp hours per week used by all loads.						_____ - ⑨
Divide line ⑨ by 7 days. This is total average amp hours per day.						Daily Amp Hour Usage = <input style="width: 80px;" type="text"/> - ⑩

➤ Calculate how many Solar Panels you will need

Total average amp hours per day	_____ - ①
Divide line ① by 0.8 to compensate for loss from battery charge/discharge	_____ - ②
Average sun hours per day in your area	_____ - ③
Divide line ② by line ③. for total amps required	_____ - ④
Multiply line ④ by 1.15 to correct for generating loss.	_____ - ⑤
Continuous non-sunshine days in your area	_____ - ⑥
Multiply line ⑤ and line ⑥ for total solar array amps required.	_____ - ⑦
Peak amps of solar module used	_____ - ⑧
Total number of solar modules in parallel. Divide line ⑦ by ⑧.	_____ - ⑨
Round off to the next highest whole number.	Number of Solar Panels = <input style="width: 80px;" type="text"/> - ⑩

➤ Calculate what size of Batteries you will need

Total average amp hours per day	_____ - ①
Divide line ① by 0.8 to compensate for loss from battery charge/discharge	_____ - ②
Continuous non-sunshine days in your area	_____ - ③
Multiply line ② and line ③ for total Wh required.	_____ - ④
DC system voltage.	12 - ⑤
Divide line ④ by line ⑤ for required Ah.	_____ - ⑥
Safety factor	2 - ⑦
Multiply line ⑥ and line ⑦ for total battery capacity Ah required.	Battery Capacity = <input style="width: 80px;" type="text"/> - ⑧



Solar Powered Repeater System

- Choose the right power cable for the system
 - You should choose the correct size (gauge) of cable depending on usage of power and cable distance as indicated below for your reference.

Recommended Cable Size by Power and Distance
(DC12V system)

Total RMS Power (Watts)	Distance				
	3m 96.84ft	5m 16.40ft	10m 32.81ft	20m 65.62ft	30m 98.43ft
100W	5.3mm ² 10 gauge	5.3mm ² 10 gauge	8.4mm ² 8 gauge	13.3mm ² 6 gauge	21.2mm ² 4 gauge
200W	5.3mm ² 10 gauge	8.4mm ² 8 gauge	13.3mm ² 6 gauge	21.2mm ² 4 gauge	33.6mm ² 2 gauge
300W	8.4mm ² 8 gauge	13.3mm ² 6 gauge	21.2mm ² 4 gauge	33.6mm ² 2 gauge	53.5mm ² 0 gauge
500W	13.3mm ² 6 gauge	21.2mm ² 4 gauge	33.6mm ² 2 gauge	53.5mm ² 0 gauge	67.4mm ² 00 gauge

American Wire Gauge (AWG):

AWG gauge	Wire Size mm ²	Ohms per 1000 ft	Ohms per km
0000	107.22	0.0490	0.1607
000	85.01	0.0618	0.2027
00	67.43	0.0779	0.2555
0	53.49	0.0983	0.3224
1	42.41	0.1239	0.4064
2	33.62	0.1563	0.5127
3	26.67	0.1970	0.6462
4	21.15	0.2485	0.8151
5	16.77	0.3133	1.0276
6	13.30	0.3951	1.2959
7	10.55	0.4982	1.6341
8	8.37	0.6282	2.0605
9	6.63	0.7921	2.5981
10	5.26	0.9989	3.2764
11	4.17	1.2600	4.1328
12	3.31	1.5880	5.2086
13	2.63	2.0030	6.5698
14	2.08	2.5250	8.2820

- Choose the right controller for the system
 - Rated Solar Current should be more than Rated Power of Solar Panel.
 - Rated Load Current should be sufficient to cover overall load current.
- Choose right Inverter for the system
 - Make sure input voltage and out put voltage for the system.
 - Rated Load Current should be sufficient to cover overall load current.



4-5 Wind-Solar Hybrid Powered Repeater System

DC load only Wind-Solar Hybrid Power system

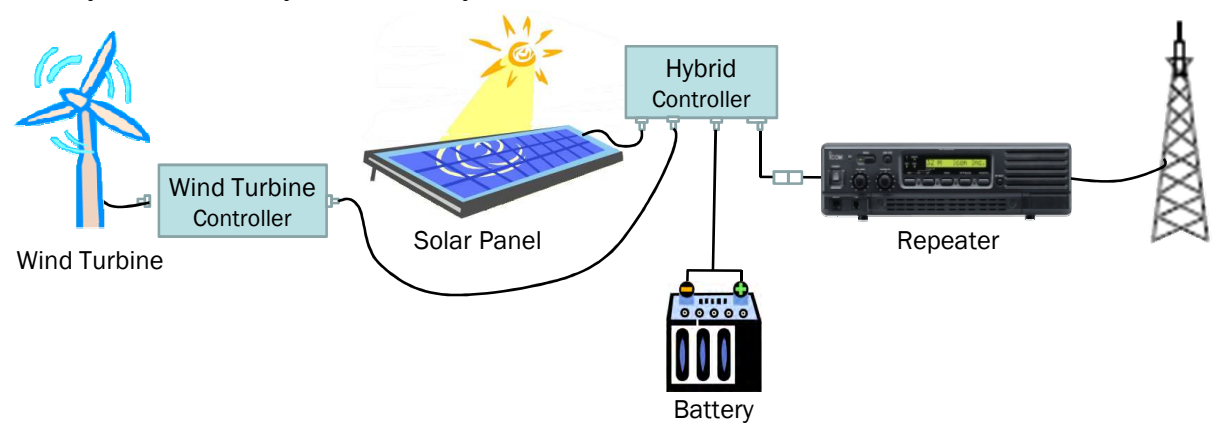

Descriptions	Model Number	Quantity
Wind Power Generator		
Wind Power Controller		
Solar Panel		
Hybrid Controller		
Battery		
Repeater		
Antenna		

DC and AC load combined Wind-Solar Hybrid system

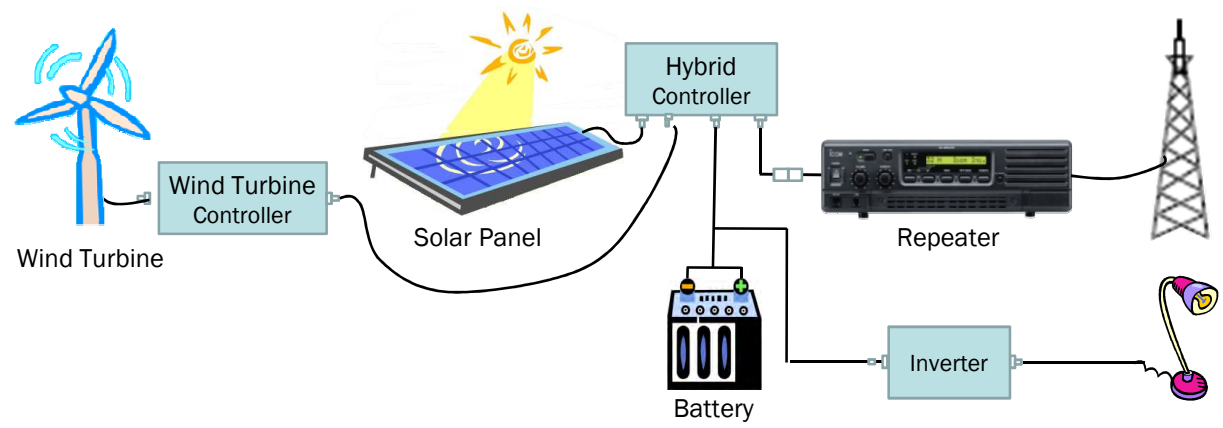

Descriptions	Model Number	Quantity
Wind Turbine		
Wind Turbine Controller		
Solar Panel		
Hybrid Controller		
Battery		
Inverter		
Repeater		
Antenna		



Wind-Solar Hybrid Powered Repeater System

➤ **Wind-Solar Hybrid power system**

In order to design a wind-solar hybrid power system you'll have to first determine your estimated electrical needs and available resources to generate electric power.

Check there are enough wind resources available at the location, and check there is enough sun light available at the location, to determine the type of generation system to make.

Wind turbine power

Wind is the "fuel" for your wind generator. The power in the wind can be transferred to electric power. The amount of transferred power is directly proportional to the density of the air, the area swept out by the rotor, and the cube of the wind speed.

$$P = \frac{1}{2} \alpha \rho \pi r^2 v^3$$

The power P available in the wind is given by:

- P = power in watts
- α = efficiency constant
- ρ = mass density of air in kilograms per cubic meter
- r = radius of the wind turbine in meters
- v = velocity of the air in meters per second

Efficiency

Depends on make and model of wind turbine which you choose.

Density

The higher a wind generator is from sea level, the lower the air density. Air density is directly proportional to the output of your turbine.

The figure below should be used in your calculation depending on the height from sea level of your installation site.

0 - 150 m	1 - 500 ft	100%
150 - 300 m	500 - 1000 ft	97%
300 - 600 m	1000 - 2000 ft	94%
600 - 900 m	2000 - 3000 ft	91%
900 - 1200 m	3000 - 4000 ft	88%
1200 - 1500 m	4000 - 5000 ft	85%
1500 - 1800 m	5000 - 6000 ft	82%
1800 - 2100 m	6000 - 7000 ft	79%
2100 - 2400 m	7000 - 8000 ft	76%
2400 - 2700 m	8000 - 9000 ft	73%
2700 - 3000 m	9000 - 10000 ft	70%

Radius

Depends on make and model of wind turbine which you choose.

Velocity

Wind maps are available for many countries which will give you an idea of the wind resource at the site where you are planning to install. Check out these maps and see if you have sufficient wind resource.

Reference of Wind Turbine Power generation figure, model Z-500 from Zephyr

Wind blow hours		5 hours			8 hours			12 hours		
Mean wind Velocity m/s	Gen. output W	Daily mean velocity m/s	Gen. power Wh	Monthly gen. power kWh	Daily mean velocity m/s	Gen. power Wh	Monthly gen. power kWh	Daily mean velocity m/s	Gen. power Wh	Monthly gen. power kWh
4	15	0.8	75	2.3	1.3	120	3.7	2.0	180	5.5
8	120	1.7	600	18.3	2.7	960	29.2	4.0	1440	43.8
12.5	400	2.6	2000	60.8	4.2	3200	97.3	6.3	4800	146.0

Other considerations

- Wind speeds increase with height. In general, the higher the tower, the more power the wind system can produce.
- How many No wind days to cover
- How many No sun shine days to cover
- How to split duty between wind and solar power
- Wind And Solar Often Have Seasonally Complimentary Resources
 - Summer: Low Wind / High Solar
 - Winter: High Wind / Low Solar

The sample list of wind and solar power components available in the market

➤ Wind Turbines

Model No.	Descriptions
Southwest Windpower (http://www.windenergy.com/index_wind.htm)	
Air-X Land-12	Wind Turbine, Rated Power 400 watts at 28 mph /12.5 m/s
WHISPER 100	Wind Turbine, Rated Power: 900 watts at 28 mph / 12.5 m/s
WHISPER 200	Wind Turbine, Rated Power: 1000 watts at 26 mph / 11.6 m/s
Zephyr (http://www.zephyreco.co.jp/en/index.htm)	
Z-1000	Wind Turbine, Rated Power: 1kW at 12.5m/s

➤ Solar panels

Model No.	Descriptions
SHELL SQ SERIES	
SQ70	Solar panel, maximum output power: 70W
SQ75	Solar panel, maximum output power: 75W
SQ80-P	Solar panel, maximum output power: 80W
SQ85-P	Solar panel, maximum output power: 85W
Sharp (www.sharppusa.com/solar)	
NE-80 EJEA	Solar panel, maximum output power: 80W
NE-165U5	Solar panel, maximum output power: 165W

➤ Controllers and other components

Model No.	Descriptions
Morningstar (www.morningstarcorp.com)	
PS-30M	Solar Charge Controller, Rated Solar Current: 30A
TriStar-45	Three-function Solar Controller, Rated Solar Current: 45A
TriStar-60	Three-function Solar Controller, Rated Solar Current: 60A
SureSine™	Pure Sine Wave Inverter, output power: 300w
Zephyr (http://www.zephyreco.co.jp/en/index.htm)	
PC-100	Power controller, Rated output power: 1440W
PV-100	Solar battery controller, Rated output power: 1440W
HS-600-12	DC/AC inverter, Continuous output: 600W
HS-350-12	DC/AC inverter, Continuous output: 350W
Xantrex Technology (http://www.xantrex.com/index.asp)	
C35	Solar Charge Controller, Rated Solar Current: 35A
XPower Inverter 300	230 VAC/50 Hz, output power: 300W
XPower Inverter 500	230 VAC/50 Hz, output power: 500W

NOTE: The above listed components were available when we prepared this material. However as we do not control availability of these products there is the possibility they may no longer be available. Please contact the local supplier for availability of the above components if necessary.

☐ Troubleshooting

The following chart is designed to help correct problems which are not equipment malfunctions.

If you are unable to locate the cause of a problem or solve it through the use of this chart, contact the nearest Icom Dealer or Service Center

PROBLEM	POSSIBLE CAUSE	SOLUTION	REF.
Power does not come on when [POWER] switch is ON.	<DC operation> <ul style="list-style-type: none"> DC power cable is improperly connected. <AC/DC common> <ul style="list-style-type: none"> Fuse is blown. 	<ul style="list-style-type: none"> Re-connect the DC power cable correctly. Check the cause, then replace the fuse with a spare one. (Fuses are installed in the internal REG unit and LOGIC unit.) 	
No sounds from the speaker.	<ul style="list-style-type: none"> Volume level is too low. The squelch is closed. The audio mute function is activated. A selective call or squelch function is activated such as 2/5 tone call or tone squelch. While in base operating mode, the repeater is in the transmitting condition. 	<ul style="list-style-type: none"> Rotate [VOLUME] clockwise to obtain a suitable listening level. While in base operating mode, rotate [SQUELCH] to counterclockwise to open the squelch. Push [SP MUTE] to the audio mute function OFF Turn the appropriate function OFF. Push [PTT] on the microphone to receive or check the PTT line of an external unit, if connected. 	
Sensitivity is low and only strong signals are audible.	<ul style="list-style-type: none"> Antenna feedline or the antenna connector has a poor contact or short-circuited. 	<ul style="list-style-type: none"> Check and re-connect (or replace if necessary), the antenna feedline or antenna connector. 	
Received signal cannot be understood.	<ul style="list-style-type: none"> Optional voice scrambler is turned OFF. Scrambler code is not set correctly. 	<ul style="list-style-type: none"> Turn the optional voice scrambler ON. Reset the scrambler code. 	
Output power is too low.	<ul style="list-style-type: none"> Output power is set to Low. 	<ul style="list-style-type: none"> Push channel selector to select the high power operating channel. 	
No contact possible with another station.	<ul style="list-style-type: none"> The other station is using tone squelch. While in base operating mode, the repeater is set to duplex. 	<ul style="list-style-type: none"> Turn the tone squelch function ON. Set the repeater to simplex, when other transceiver is set to simplex. 	

☐ Fuse replacement

If a fuse blows or the repeater stops functioning, try to find the source of the problem, and replace the damaged fuse with a new, rated fuse.

⚠ WARNING: DISCONNECT the AC power cable and/or DC power cable from the repeater. Otherwise, there is danger of electric shock and/or equipment damage.

❖ Line fuse replacement [DC13.6V version]

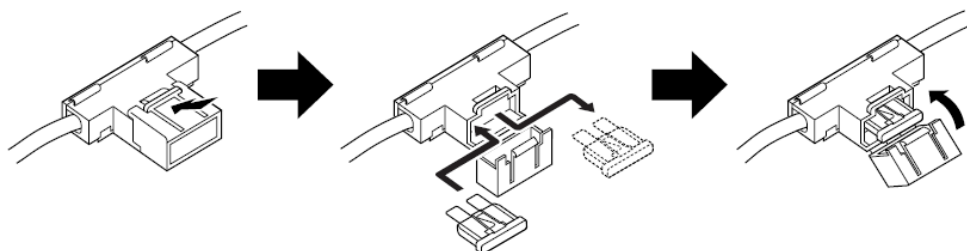

➤ **LOGIC unit**

- ① Remove the bottom cover as shown on page 23.
- ② Remove 8 screws from the LOGIC shielding plate, then remove the plate.

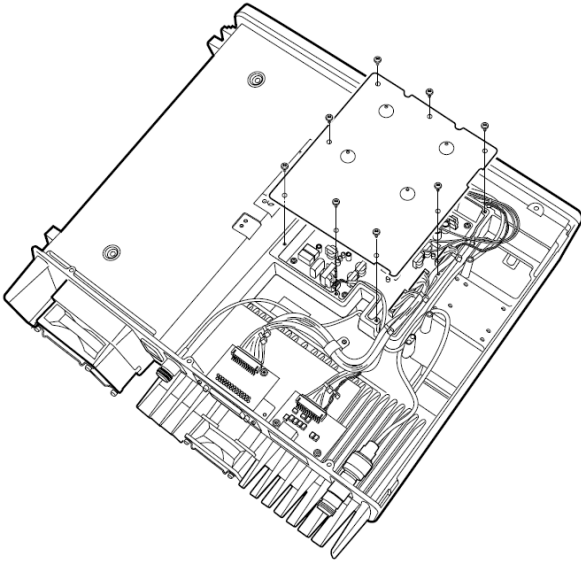

- ③ Replace the circuitry fuse as shown below.

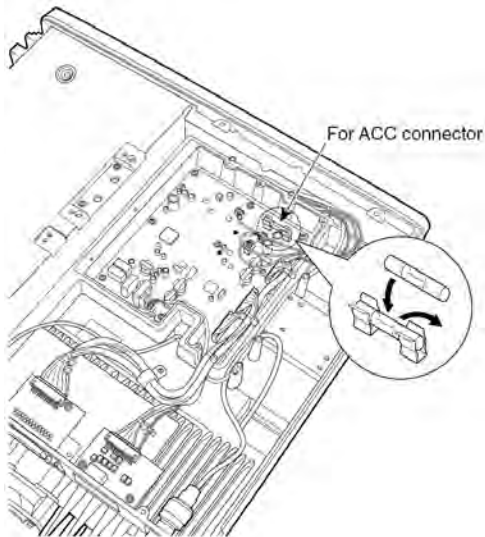

- ④ Return the LOGIC shielding plate and bottom cover.

➤ **REG unit**

- ① Remove the top cover as shown on page 23.
- ② Remove the 12 screws from the REG shielding plate, then remove the plate.

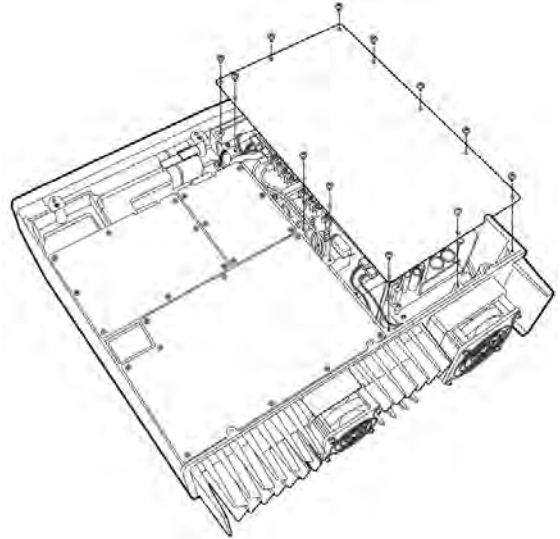

- ③ Replace the circuitry fuse as shown below.

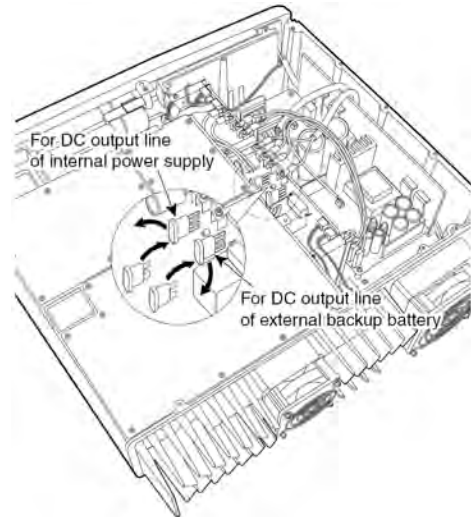

- ④ Return the REG shielding plate and top cover.



A-1 Promotional Materials

- The following Catalogues are available on the Icom web site.

URL: <http://www.icom.co.jp/world/index.html>

< Home Page >

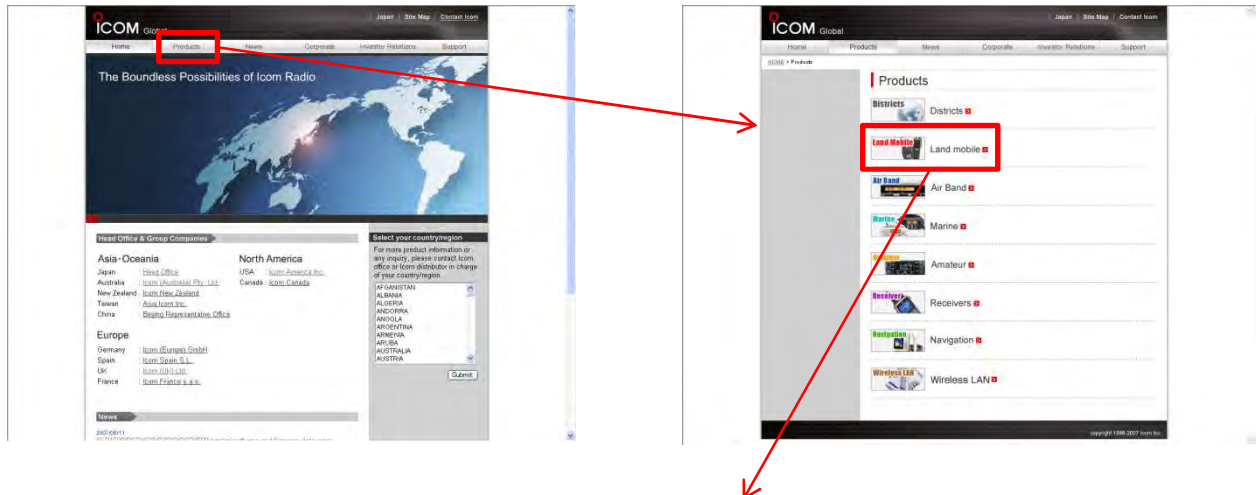

- The following Materials are available upon request through local Icom Distributors in your region.

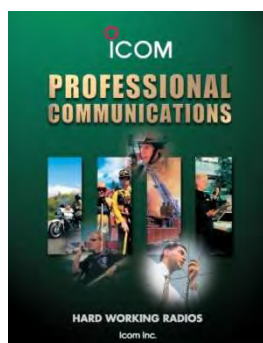

LMR
Full line brochure



LMR Poster



A-2 Instruction Manuals and Other Materials

- The following Instruction Manuals are available on the Icom web site.

URL: <http://www.icom.co.jp/world/index.html>

< Home Page >



< Support Center Page >

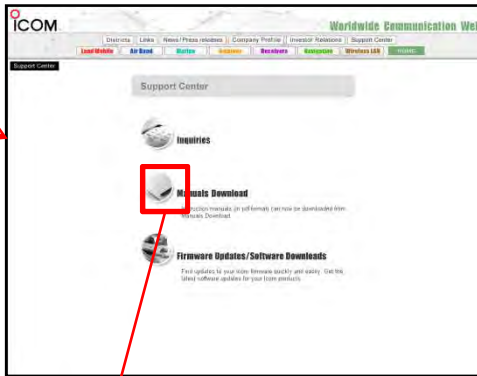



Instruction manual
IC-FR3000
IC-FR4000



Remote Control manual
IC-FR3000
IC-FR4000

- The following Materials are available upon request through local Icom Distributors in your region.

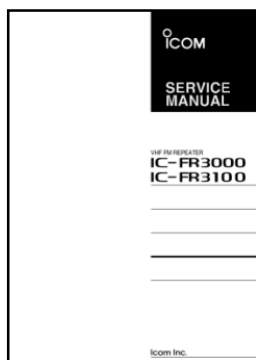

Service Manual
IC-FR3000
IC-FR3100

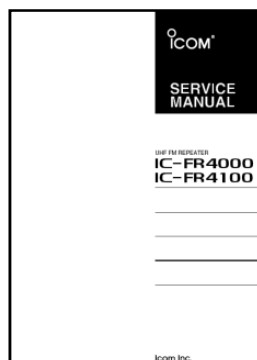

Service Manual
IC-FR4000
IC-FR4100





Icom Inc. 1-1-32, Kami-minami, Hirano-ku, Osaka 547-0003, Japan Phone: +81 (06) 6793 5302 Fax: +81 (06) 6793 0013 URL: <http://www.icom.co.jp/world/index.html> **Count on us!**

Icom America Inc.

2380 116th Avenue NE,
Bellevue, WA 98004, U.S.A.
Phone: +1 (425) 454-8155
Fax: +1 (425) 454-1509
E-mail: sales@icomamerica.com
URL: <http://www.icomamerica.com>

Icom Canada

Glenwood Centre #150-6165 Highway 17,
Delta, B.C., V4K 5B8, Canada
Phone: +1 (604) 952-4266
Fax: +1 (604) 952-0090
E-mail: info@icomcanada.com
URL: <http://www.icomcanada.com>

Icom (Australia) Pty. Ltd.

Unit 1 / 103 Garden Road,
Clayton VIC 3158 Australia
Phone: +61 (03) 9549 7500
Fax: +61 (03) 9549 7505
E-mail: sales@icom.net.au
URL: <http://www.icom.net.au>

Icom New Zealand

146A Harris Road, East Tamaki,
Auckland, New Zealand
Phone: +64 (09) 274 4062
Fax: +64 (09) 274 4708
E-mail: inquiries@icom.co.nz
URL: <http://www.icom.co.nz>

Icom (Europe) GmbH

Communication Equipment
Himmelgelster Str. 100,
D-40225 Düsseldorf, Germany
Phone: +49 (0211) 346047
Fax: +49 (0211) 339639
E-mail: info@icom-europe.com
URL: <http://www.icom-europe.com>

Icom Spain S.L.

Ctra. Rubi, No. 88 "Edificio Can Castanyer"
08190, Sant Cugat del Valles, Barcelona, Spain
Phone: +34 (93) 590 26 70
Fax: +34 (93) 590 04 46
E-mail: icom@icomspain.com
URL: <http://www.icomspain.com>

Icom (UK) Ltd.

Unit 9, Sea St., Herne Bay,
Kent, CT6 8LD, U.K.
Phone: +44 (01227) 741741
Fax: +44 (01227) 741742
E-mail: info@icomuk.co.uk
URL: <http://www.icomuk.co.uk>

Icom France s.a.s.

Zac de la Plaine,
1 Rue Brindejonc des Moullinais, BP 45804,
31505 Toulouse Cedex 5, France
Phone: +33 (5) 61 36 03 03
Fax: +33 (5) 61 36 03 00
E-mail: icom@icom-france.com
URL: <http://www.icom-france.com>

Icom Polska

Sopot, 3 maja 54, Poland
Phone: +48 (58) 550 7135
Fax: +48 (58) 551 0484
E-mail: icompolska@icompolska.com.pl
URL: <http://www.icompolska.com.pl>

Asia Icom Inc.

6F No. 68, Sec. 1 Cheng-Teh Road,
Taipei, Taiwan, R.O.C.
Phone: +886 (02) 2559 1899
Fax: +886 (02) 2559 1874
E-mail: sales@asia-icom.com
URL: <http://www.asia-icom.com>

Beijing Icom Ltd.

10007, Long Silver Mansion, No.88, Yong Ding
Road, Haidian District, Beijing, 100039, China
Phone: +86 (010) 5889 5391/5392/5393
Fax: +86 (010) 5889 5395
E-mail: bjicom@bjicom.com
URL: <http://www.bjicom.com>

Your local distributor/dealer: